



**Translation of original
operating instructions**

**Deep Aerator
TERRA SLIT**

499.001

From machine ID no. :

Version : January 2010

499 99 09



EC-Declaration of Conformity

We

**Wiedenmann GmbH
Am Bahnhof
89192 Rammingen**

declare under our sole responsibility, that the product

**Deep Aerator
TERRA SLIT**

to which this declaration relates conforms to the relevant basic safety and health requirements of EC Directive 2006/42/EC.

Rammingen, the 26.04.2010	Horst Wiedenmann
(Place and date of issue)	Managing Partner
	(Name, function and signature of the authorized person)

Rammingen, the 26.04.2010	Peter Rischar
(Place and date of issue)	Manager of Technical Office Authorized Representative for Technical Documentation
	(Name, function and signature of the authorized person)

Note: The Declaration of Conformity loses its validity if alterations are made to the equipment without the consent of the manufacturer.



Declaration of Conformity

We

**Wiedenmann GmbH
Am Bahnhof
89192 Rammingen**

state that the product

**Deep Aerator
TERRA SLIT**

to which this declaration relates conforms to the requirements of
EC Directive 2006/42/EC.

Rammingen, the 26.04.2010	Karl Wiedenmann
(Place and date of issue)	Sales Manager
	(Name, function and signature of the authorized person)

Rammingen, the 26.04.2010	Harald Reuen
(Place and date of issue)	Production Manager
	(Name, function and signature of the authorized person)

**Wiedenmann GmbH
Am Bahnhof
D 89192 Rammingen
Tel. No. : +49 (0) 7345 / 953-0
Fax No. : +49 (0) 7345 / 953 233
e-mail : info@wiedenmann.de
Internet : <http://www.wiedenmann.de>**

Introduction

PLEASE READ THESE OPERATION INSTRUCTIONS CAREFULLY in order to familiarize yourself the correct method of operation and maintenance and in order to avoid personal injuries or damage to the machine.

This manual and safety decals on your machine may also be available in other languages (see your dealer to order).

THIS MANUAL SHOULD BE CONSIDERED a permanent part of your machine and should remain with the machine when you sell it.

MEASUREMENTS in this manual are given in both metric and customary U.S. unit equivalents. Only use suitable parts and screws. Metric and inch fasteners may require a specific metric or inch wrench.

RIGHT-HAND AND LEFT-HAND sides refer to the direction of travel the implement when going forward.

WRITE PRODUCT IDENTIFICATION NUMBERS (P.I.N.) in the Specification or Identification Numbers section. Please ensure that all numbers are correctly recorded. to help in tracing the machine should it be stolen. Your dealer also requires this number when you order spare parts. File the identification numbers in a secure place away from the machine.

BEFORE DELIVERING THIS MACHINE, your dealer performed a pre-delivery inspection to ensure best performance.

THIS MACHINE IS DESIGNED EXCLUSIVELY for commercial use and standard applications in the maintenance of grass and turf for slitting, loosening or aerating sports fields and golf courses ("INTENDED USE").

Use in any other way is considered contrary to the intended use. The manufacturer accepts no liability for damage or injury resulting from this misuse, and these risks must be borne solely by the user. Using the equipment in accordance with the specifications also includes observance of the operating and maintenance conditions as specified by the manufacturer.

PREDICTABLE MISUSE AND ABUSE. Persons and objects must not be transported with the machine attached.

THIS MACHINE SHOULD BE OPERATED, serviced and repaired only by persons familiar with all its particular characteristics and acquainted with the relevant safety requirements (accident prevention). The accident prevention regulations, all other generally recognized regulations on occupational health and safety, and the road traffic regulations must be observed at all times. Any unauthorized modifications carried out on this machine will relieve the manufacturer of all liability for any resulting damage or injury.

NOTE THE INSTRUCTIONS

for driving on public roads:

"This machine is not suitable for travel on Highways or public roads. It requires additional equipment for this (lighting kit, warning signs for slow vehicles/SMV sign, reflectors). Please contact us if you wish to purchase this optional equipment "

CONTENTS

Page

1.0. Safety.....	6&14
1.1. Safety Decals.....	11&12
1.2. Safety Equipment.....	13
1.3. Safety instructions.....	14
2.0. Assembly.....	15&22
2.1. General.....	15
2.2. Installing tines.....	16
2.3. Mounting hollow tines and half disks.....	17
2.4. Mounting blades and half disks.....	18
2.5. Mounting additional weights.....	19
2.6. Installing hydraulic weight transfer.....	19
2.7. Attaching rear roller.....	20
2.8. Installing moving gear with drawbar.....	21&22
3.0. Transport.....	23&26
3.1. General.....	23
3.2. Transporting TERRA SLIT.....	24&25
3.3. Transportation with three-point attachment.....	26
3.4. ansportation with drawgear.....	26
4.0. Connecting to the Tractor.....	27&29
4.1. General.....	27
4.2. Ballast.....	27
4.3. Attachment to the tractor.....	28
4.4. Attachment to the tractor.....	29
4.5. Drawbar support.....	29
5.0. Disconnecting from the Tractor.....	30&31
5.1. General.....	30
5.2. Unhitching TERRA SLIT.....	30
5.3. Unhitch TERRA SLIT.....	31
6.0. Before Using.....	32&34
6.1. General.....	32
6.2. Indicator and adjustment components.....	33
6.3. Adjusting TERRA SLIT.....	34
6.4. Adjusting rear roller.....	34
7.0. Operation.....	35&37
7.1. General.....	35
7.2. Driving properties.....	36
7.3. Working with the TERRA SLIT.....	36
7.4. Faults and remedies.....	37
8.0. Maintenance.....	38&46
8.1. General.....	38
8.2. Maintenance and inspection list.....	39
8.3. Lubrication.....	40
8.4. Cleaning the TERRA SLIT.....	41
8.5. Care and maintenance of the hydraulic system.....	42
8.6. Hydraulic connection diagram.....	43
8.7. Wheels and tires.....	44
8.8. Disassembly / Disposal.....	45
8.9. Unauthorized modification and spare part manufacturing.....	46
9.0. Equipment.....	47&49
9.1. Equipment supplied.....	47
9.2. Approved machine combinations.....	47
9.3. Set of tines.....	48
9.4. Optional equipment.....	49
10.0. Specifications.....	50&55

1.0. Safety

Recognize safety information

This is the safety alert symbol. When you see this symbol on your machine or in this manual, be aware of the potential for personal injury.

Follow recommended precautions and safe operating practices.



Follow safety instructions

Carefully read all safety messages in this manual and warning signs on your machine. Keep warning signs in good condition. Replace missing or damaged warning signs. Make sure that new equipment, components and replacement parts include the current warning signs. Replacement warning signs are available from your dealer.

Learn how to operate the machine and use the controls properly. Do not let anyone operate without instruction.

Keep your machine in proper working condition. Unauthorized modifications to the machine may impair the function and/or safety and affect machine life.

If you do not understand any part of this manual and need assistance, contact your dealer.

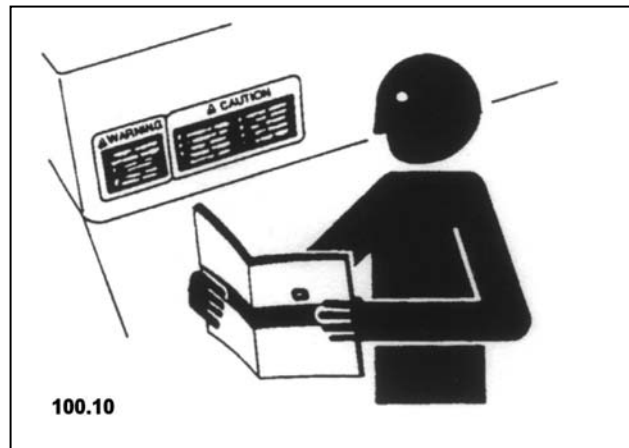

1.0. Safety

Observe road traffic regulations

Always observe local road traffic regulations when using public roads.

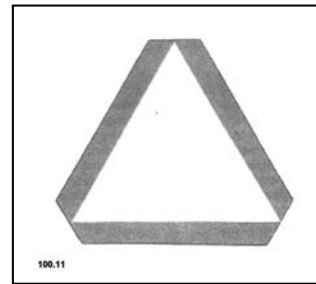

Wear protective clothing

Wear close fitting clothing and personal protective equipment appropriate to the job.

Prolonged exposure to loud noise can cause impairment or loss of hearing.

Wear a suitable hearing protective device such as earplugs to protect against objectionable or uncomfortably loud noises.

Operating equipment safely requires the full attention of the operator. Do not wear radio or music headphones while operating the machine.



Stay clear of rotating drive shafts

Entanglement in a rotating drive shaft may cause serious injury or death.

Keep all drive shaft guards in place at all times. Make sure rotating shields can turn freely.

Wear close fitting clothing. Stop the engine and make sure PTO shaft is stopped before making adjustments, connections, or cleaning out PTO-driven equipment.



1.0. Safety

Guard and shields

Keep guards and shields in place all the times. Ensure that they are in good condition and installed correctly.

Always disengage the drive components, turn off engine and remove key before removing any guards or shields.

Keep hands, feet and clothing away from moving parts.

Avoid high-pressure fluids

Escaping fluid under pressure can penetrate the skin causing serious injury.

Avoid the hazard by relieving pressure before disconnecting hydraulic or other lines. Tighten all connections before applying pressure.

Hydraulic oil escaping from a small leak is virtually invisible, therefore search for leaks with a piece of cardboard. Protect hands and body from high pressure fluids.

If an accident occurs, see a doctor immediately. Any fluid injected into the skin must be surgically removed within a few hours or gangrene may result. Doctors unfamiliar with this type of injury should check a reliable medical reference.

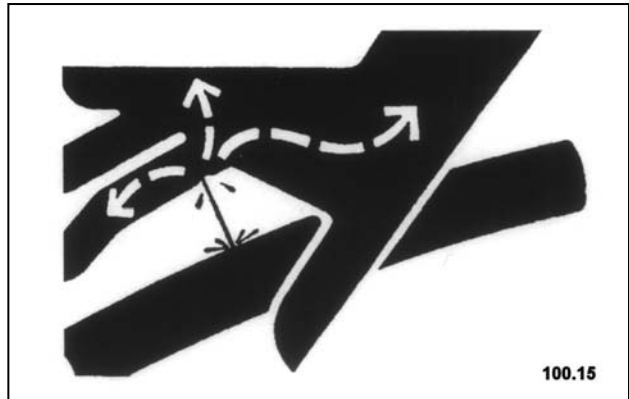

1.0. Safety

Use safety lights and devices

Slow moving tractors with attachments or towed equipment and self-propelled machines are a particular hazard on public roads. Frequently check for traffic from the rear, especially in turns, and use hand signals or turn signal lights.

Use headlights, flashing warning lights, and turn signals day and night. Follow local regulations for equipment lighting and marking. Keep lighting and marking visible and in good working order. Replace or repair lighting and marking that has been damaged or lost. An implement safety lighting kit is available from your dealer.

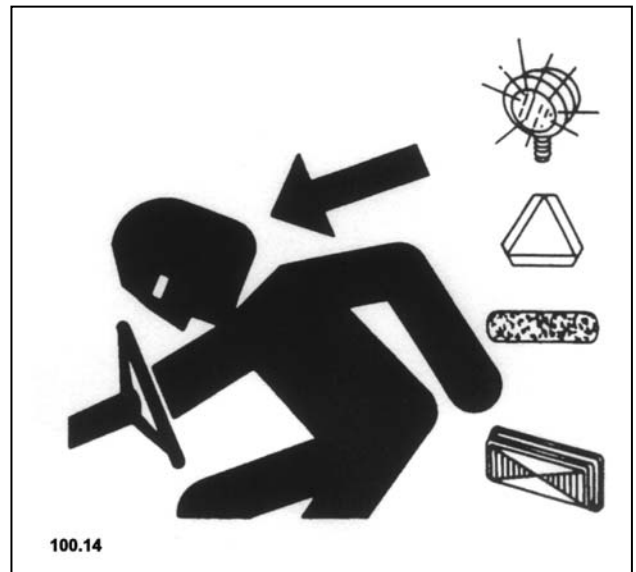

Avoid heating near pressurized fluid lines

Flammable spray can be generated by heating near pressurized fluid lines, resulting in severe burns to yourself and bystanders. Do not heat by welding, soldering, or use a welding torch near pressurized fluid lines or other flammable materials. Pressurized lines can be accidentally cut if heat goes beyond the immediate flame area.



1.0. Safety

Remove paint before welding or heating

Welding must be conducted only by persons with appropriate qualifications.

Avoid potentially toxic fumes and dust.

Hazardous fumes can be generated when paint is heated by welding, soldering, or using a torch.

Do all work outside or in a well ventilated area. Dispose of paint and solvent properly.

Remove paint before welding or heating:

- If you sand paint, avoid breathing the dust. Wear an approved respirator.
- If you use solvent or paint stripper, clean with soap and water before welding. Remove solvent or paint stripper containers and other flammable material from area. Allow fumes to disperse at least 15 minutes before welding or heating.

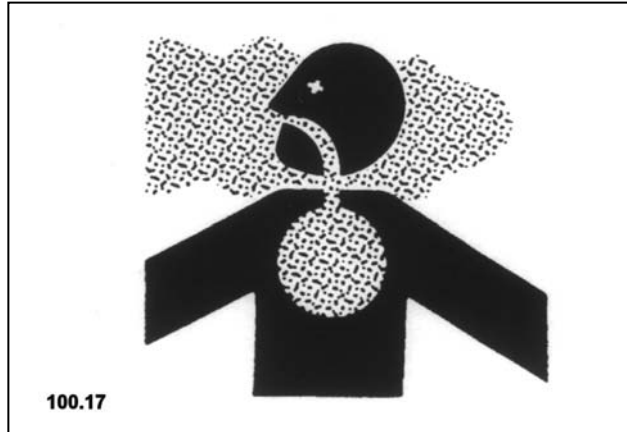

1.0. Safety

1.1. Safety Decals

Pictorial warning signs

Warning signs are attached to several important places on this machine to indicate potential danger. The hazard is identified by an exclamation point in a warning triangle. An adjacent symbol shows information on how to avoid personal injury. These safety signs, their placement on the machine and a brief explanatory text are shown below.



Operator's manual

This operator's manual contains all important information necessary for safe machine operation. Carefully observe all safety rules to avoid accidents.

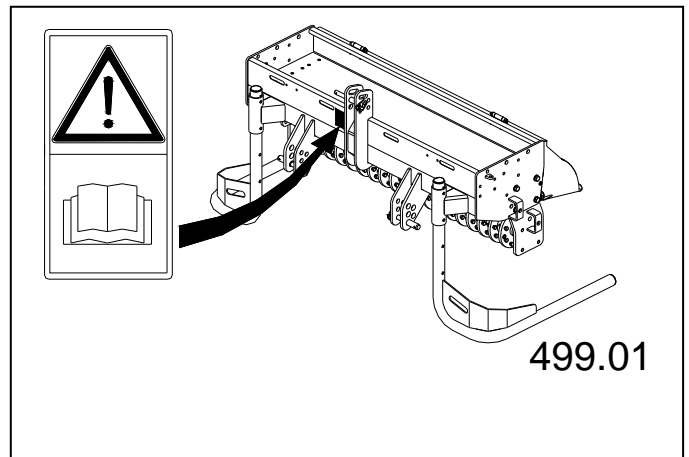

Protectors

Never reach into areas of crushing hazard as long as any parts may move.

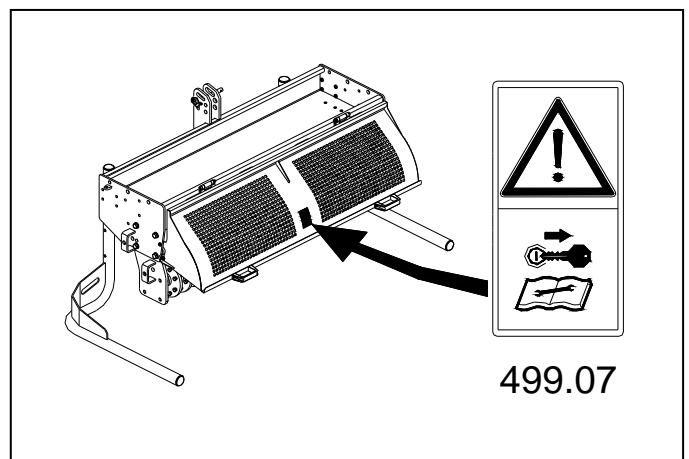

1.0. Safety

1.1. Safety Decals

Safety cover

The safety cover prevents access to the tines. The safety cover is secured with a bolt on both sides.

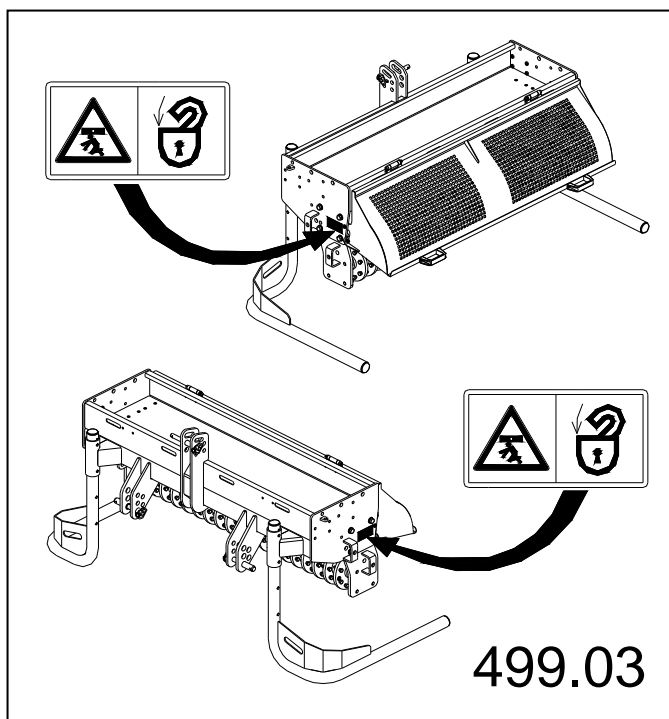

Parking position

Before parking the cocks on both hydraulic cylinders must be shut off to prevent the machine from lowering.

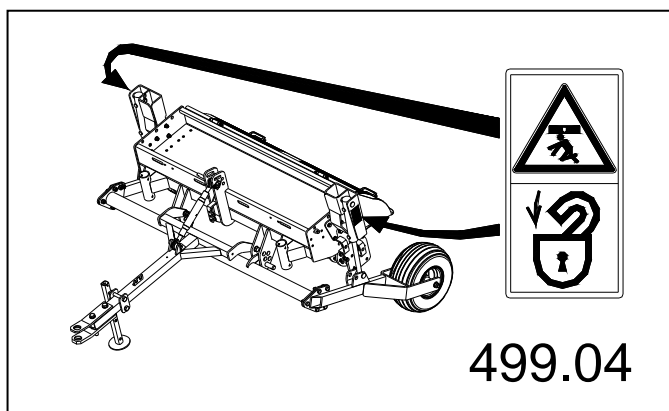

Set of tines

Never touch moving parts of the machine. Wait until they have come to a complete standstill.

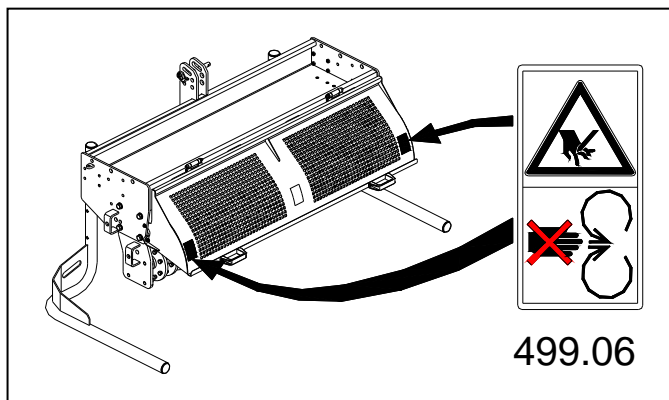

1.0. Safety

1.2. Safety Equipment

GENERAL WARNING SIGN REQUIREMENTS

A warning sign with the following safety practices or similar set of messages must be attached to the machine. The label should be visible from the operator's position, if possible.

- a) Read the operator's manual.
- b) Do not operate the machine without guards, shield, and safety devices in place and working.
- c) Do not operate the machine when children and others are around.
- d) Do not allow operation of the machine by untrained personnel.



ATTENTION - DANGER !

Never use TERRA SLIT without safety equipment. Otherwise, you expose yourself and others to extreme danger.

⇒ Moving parts may cause serious injuries.

Where to Find Safety Equipment on your Machine

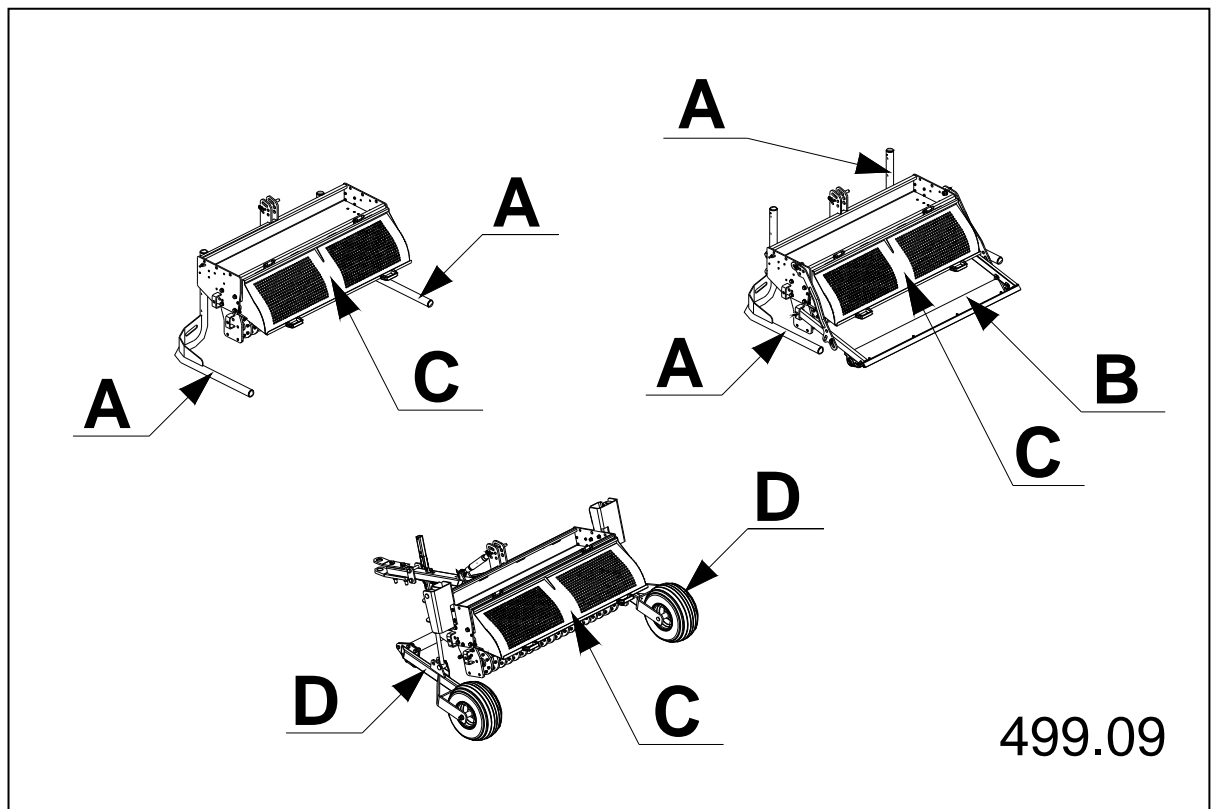

A = Permanently attached supports right and left as spacers.

B = Rear roller installed and locked on frame with retainer arms .

C = safety cover , can only be removed with tools.

D = Bolted-on moving gear right and left as spacers.

1.0. Safety

1.3. Safety instructions



- Besides the information in these operating instructions, please also observe all generally applicable safety and accident-prevention standards!
- Familiarize yourself with all equipment and operating elements and their functions before starting work. Ensure that all protective equipment has been properly installed - it is too late to do this when you have started work!
- During work operation, the user is responsible for the safety of third parties!
- Before moving off, ensure that the immediate area of the machine is clear, e.g. no children nearby. Ensure that your visibility is not impaired!
- Keep clear of the danger zone of the machine!
- Switch off the machine and the tractor motor when performing any maintenance work.
- Special care should be taken when working and turning on a slope.
- RISK OF TIPPING OVER!
- **Caution!**
The equipment version with drawbar is **NOT** approved for operation on public roads.

2.0. Assembly

2.1. General

Park TERRA SLIT with the machine supports in top position.

For this work, please use your personal protective equipment (PSA) such as: gloves, goggles, ear protectors.

If no additional weights from Wiedenmann are installed but other objects are used as ballast, note the following:

1. the approved weight as defined in the specifications must be maintained.
2. the objects must be fixed in the ballast frame to prevent slippage.

2.0. Assembly

2.2. Installing tines

There are two options for installing the tines:

1. Pitch 6 in.
for 40 tines

2. Pitch 3 in.
for 76 tines

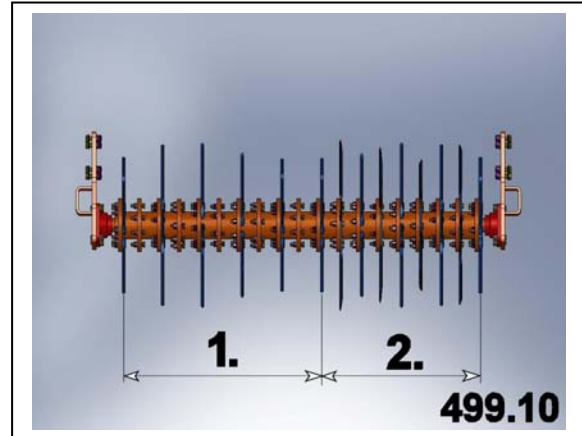

Correct position of standard tines



Correct position of intensive tines



Correct position of fine-cutting tines



2.0. Assembly

2.3. Mounting hollow tines and half disks

Version 1:

8 spoons per half-disk set are installed



Version 2:

the half-disk set is fully fitted with 16 tines



The disks are always fastened on the same side.

No more than ten half-disk sets with hollow tines may be installed.

This corresponds to a **pitch of 6 in.**



2.0. Assembly

2.4. Mounting blades and half disks

8 blades per half-disk set are mounted



Version 1:
10 half-disk sets are fixed to
every second disk

This corresponds to a
pitch of 6 in.

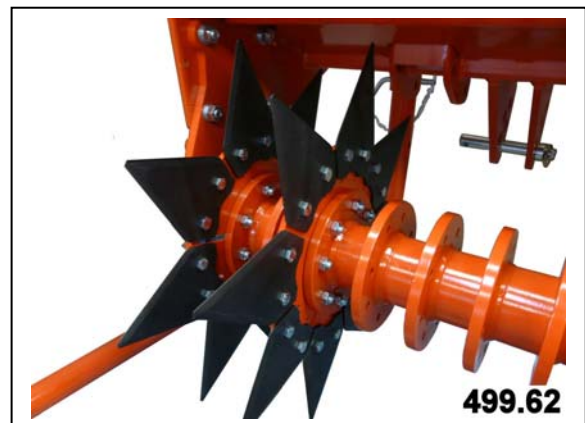

Version 2:
19 half-disk sets are fixed to
every disk

This corresponds to a
pitch of 2 in.

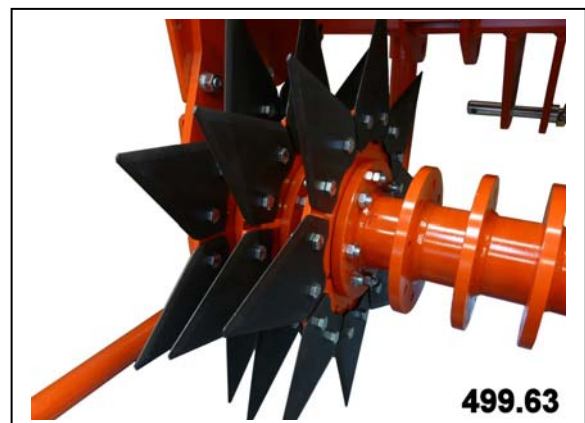

The disks are always fastened
on the same side.

2.0. Assembly

2.5. Mounting additional weights



ATTENTION DANGER !

Only perform assembly work when the machine is attached. Lower the attached machine to the ground.

Switch off the tractor and secure it against unintentional starting.

Fasten brackets (A) manually in the ballast frame on both sides.

Attach suspension to the ring bolts of the additional weight.

Lift the additional weight to the fastening position with a hoist.

Two persons are required for attachment without equipment. The load for attachment is 48.5 lb. (22 kg).

Tighten all fastening screws.

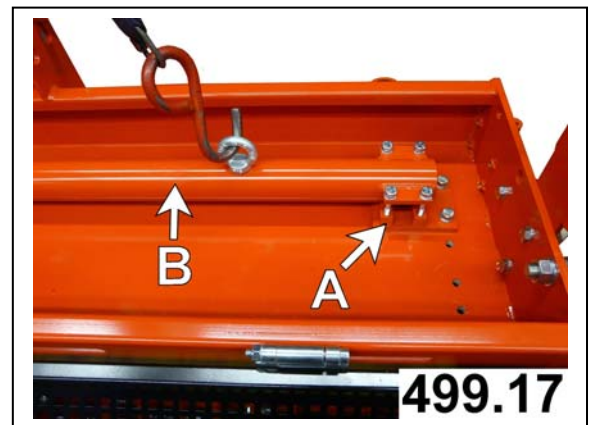
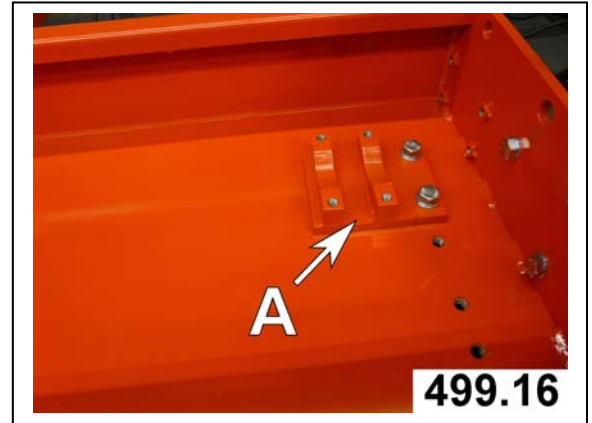

2.6. Installing hydraulic weight transfer

Fitting instructions are included with the hydraulic weight transfer.

The instructions include:

1. Important information before installation
2. Description of attachment
3. Description of adjustment
4. Important points for correct operation

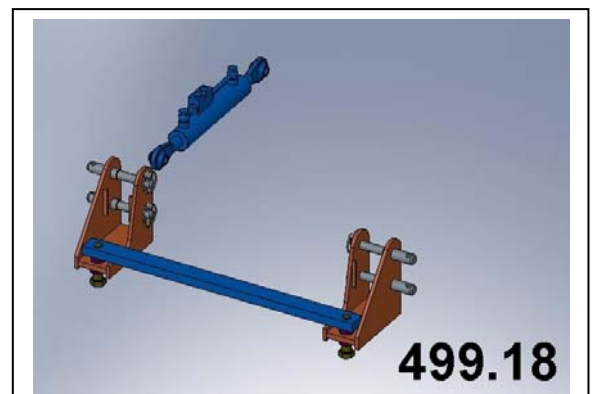

2.0. Assembly

2.7. Attaching rear roller

Two persons are required for attachment without equipment. The load for attachment is 48.5 lb. (22 kg).

Align hole (A) on the side frame with hole (B) on the frame.

Secure with pins on both sides and lock with spring clips.

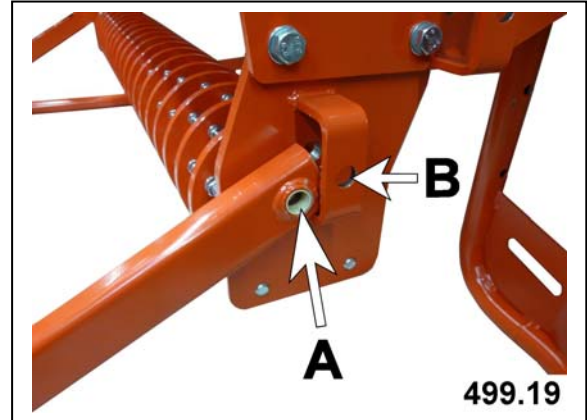

Fix bolt (C) at the matching hole at the back.

Mount and lock adjustment brace (D) on bolt.

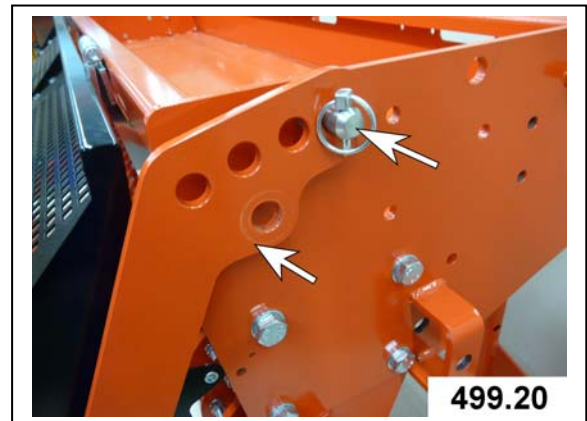

For transportation adjustment braces must be locked by inserting the pin (E) into the hole in the side frame and locking it.

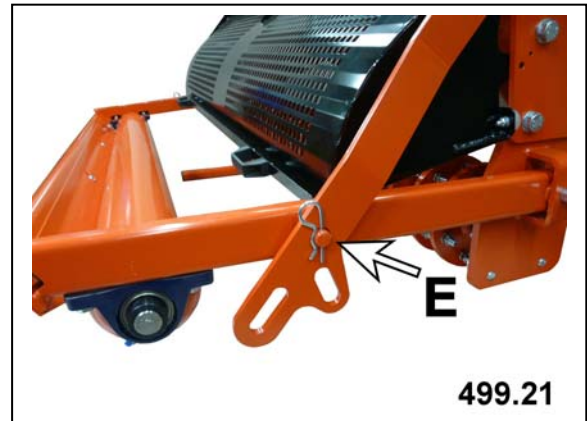

When working with the rear roller use the slot (F) only.

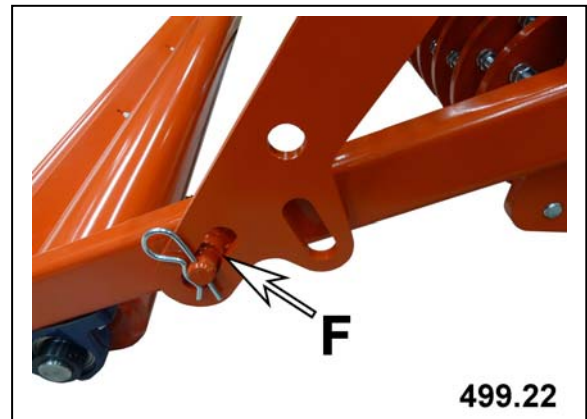

2.0. Assembly

2.8. Installing moving gear with drawbar

Two persons are required for attachment without equipment. The load for attachment is 55 lb. (25 kg).

Attach basic unit to points **(A and B)**.

Fix cylinder bearing **(C)** into the matching hole on the frame on both sides.

Tap out expansion pin on both machine supports.

Lift basic unit with hoist to remove the machine supports.

Insert cross member **(E)** as shown in Figure 499.24 into the bottom hole of the attachment shackle and lock it.

Fasten wheels with their bracket **(F)** to the cross member **(E)**.

Insert hydraulic cylinder **(G)** into the hole **(H)** in the wheel bracket **(F)** and lock it.

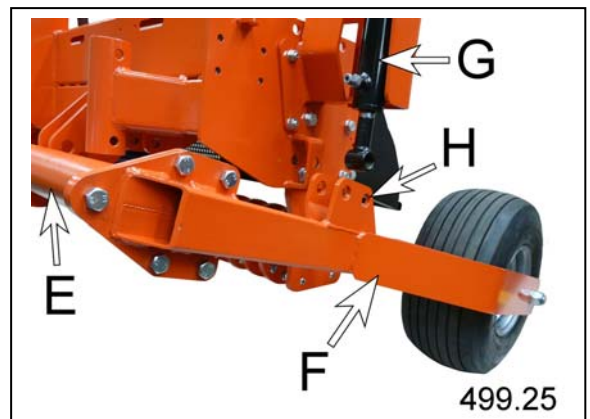
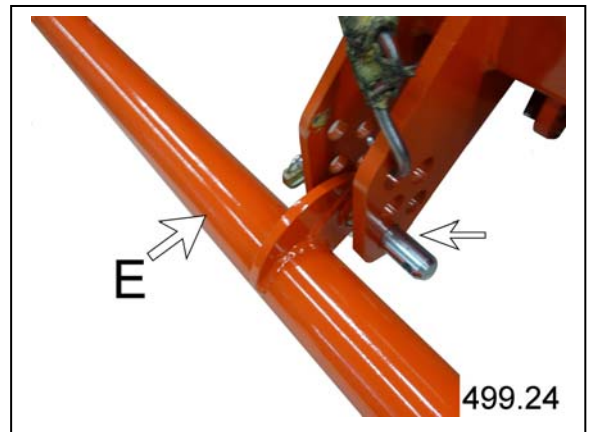
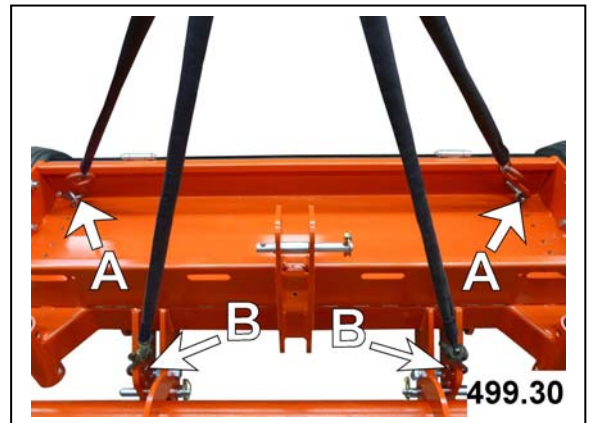

2.0. Assembly

2.8. Installing moving gear with drawbar

Fix drawbar (**J**) in the top holes in the inner shackles so the drawbar remains movable.

Insert top connecting rod (**K**) into the top hole and lock it.

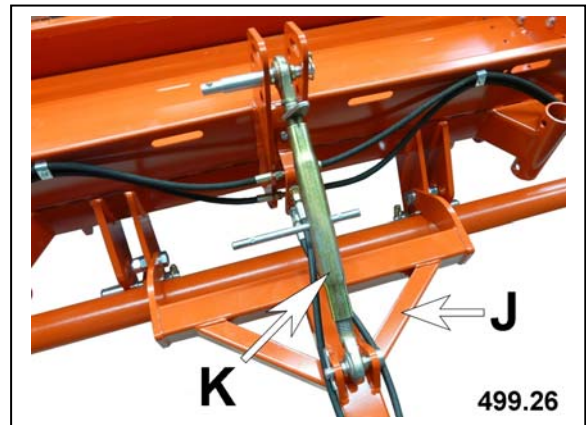

Fasten bracket (**L**) to the frame with bolt (**M**).

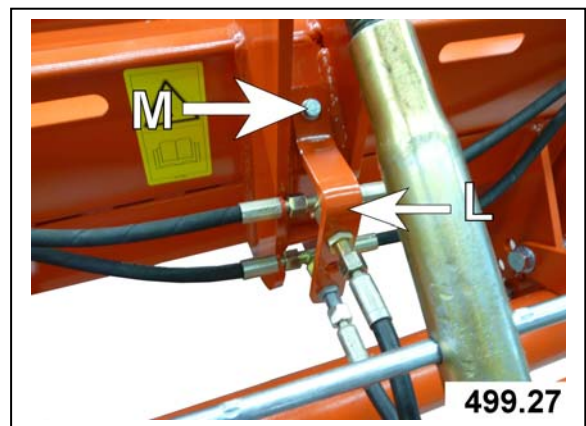

Fix the hydraulic line to the frame with the clips (**N**).

Fix the lines for connecting to the tractor to the drawbar with the clip (**P**).

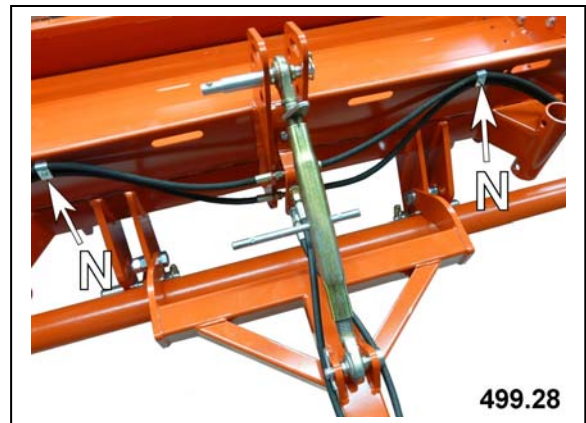

Observe the following when connecting the hydraulic lines:

- the length must be sufficient for the movements
- lines must not be damaged by movements.

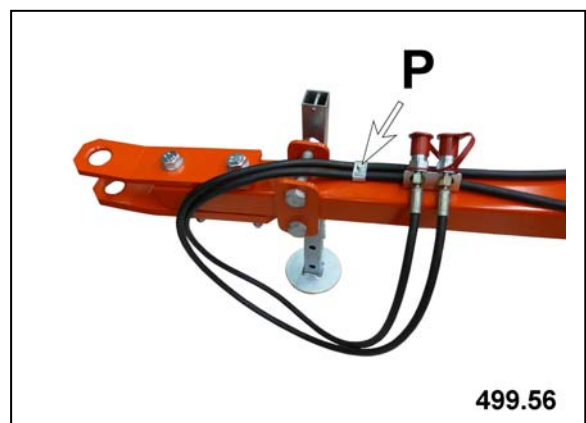

3.0. Transport

3.1. General



ATTENTION DANGER !

- TERRA SLIT is delivered fastened to a pallet.
- Use only forklift trucks, cranes or lifting equipment with a sufficient load-bearing capacity.
- Keep well clear of hoisted loads. If the load falls it may cause fatal injuries.

Improper transport and mounting of TERRA SLIT may cause:

- Injury to persons
- Damage to property.

Pay special attention to the driving direction when lifting the TERRA SLIT with the shipment frame.

We will not accept any liability for damage resulting from improper handling.

3.0. Transport

3.2. Transporting the TERRA SLIT



ATTENTION DANGER:

Be careful when cutting through the tension straps. There is a risk of being injured when the straps are cut.

3.2.1. Transport Using a Forklift

If the TERRA SLIT is still fastened to the pallet :

- move the forks into the shipping frame, (note direction of approach)
- carefully raise the shipping frame,
- unload the TERRA SLIT from the carrier vehicle when balanced,
- cut through the tension straps,
- attach the TERRA SLIT to the tractor and lift it from the pallet (See item 4.2.).

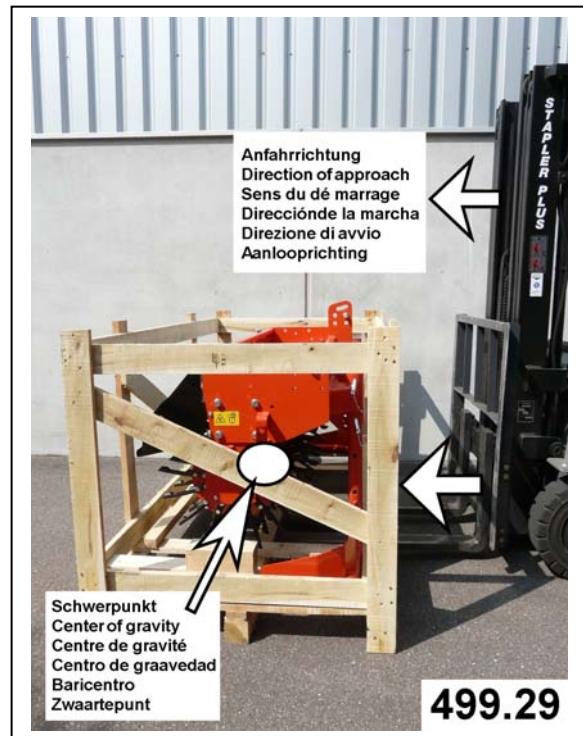

3.2.2. Transport Using a Crane

- Attach ropes or belts to the ring bolts (A) and the top hole (B) of the outer connecting plates.
- Unload the TERRA SLIT when it is securely suspended.

NOTE :

Inform the transport company and Wiedemann GmbH or the supplier immediately in writing about shipping damage or missing parts.

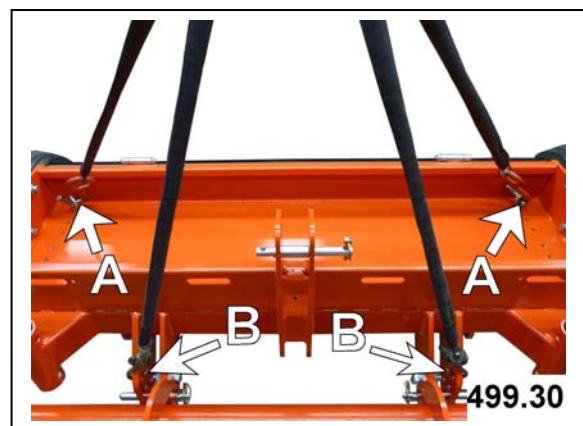

2.0. Transport

3.2. Transporting the TERRA SLIT

3.2.3. Hitching point for transport on a trailer



ATTENTION DANGER:

Note the description of removal in Section 5.2.

- RISK OF TIPPING OVER!

Tighten the belts evenly at diagonally opposite points.

- Attachment points for belts on the front of the Terra SLIT



- Attachment points for belts on the back of the Terra SLIT



3.0. Transport

3.3. Transportation with three-point attachment

Raise the attached equipment with the tractor rear hydraulics and lock to prevent accidental lowering.

Be aware of the swivel range of the attached Terra SLIT when driving on public roads.

3.4. Transportation with drawgear

Lower the moving gear of the mounted equipment hydraulically to the stop and lock to prevent accidental lowering.

Caution!

The equipment version with drawbar is **NOT** approved for operation on public roads.

4.0. Connecting to the Tractor

4.1. General



ATTENTION DANGER:

Do not exceed the max. authorized axle load of the tractor.

Always ensure there is sufficient front-axle load; the steering capability of the vehicle must be maintained. (if needed, put on ballast weights, see operator's manual of tractor).

Always pay attention to:

- The load on the three point hitch.

Attach the TERRA SLIT only to:

- the engine turned off
- the PTO shaft disengaged

4.2. Ballast

When attaching rear-mounted equipment, always ensure there is sufficient front-axle load; the steering capability of the vehicle must be maintained. Always position weights in accordance with specifications at the securing points provided.

When selecting the front weights, make sure that the approved axle loads and the approved total weight including mounted equipment are not exceeded.



IMPORTANT:

Observe the tractor specifications in the Operating Manual.

4.0. Connecting to the Tractor

4.3. Attachment to the tractor

Prerequisite for connecting:

- a three-point hitch.

NOTE:

With the three-point linkage it is essential that the assembly categories of the tractor and machine match each other.

Mounting steps:

1. Remove bottom connecting rod at pin (1a for cat.1 or 1b for cat.2) and lock with linch pin (2).
2. Mount the upper links follows: depending on the tractor, insert the bolt for category 1 with diameter (3a) and fix it with the cotter key (4). Or, for attachment with category 2, use diameter 3b.
3. Tighten the tension lock of the stabilizing chain.
4. Position the two machine supports in the top position and lock.

During operation the machine supports are in a position in which they become the hoop guard.



ATTENTION DANGER !

Check that it is correctly connected before starting operation.

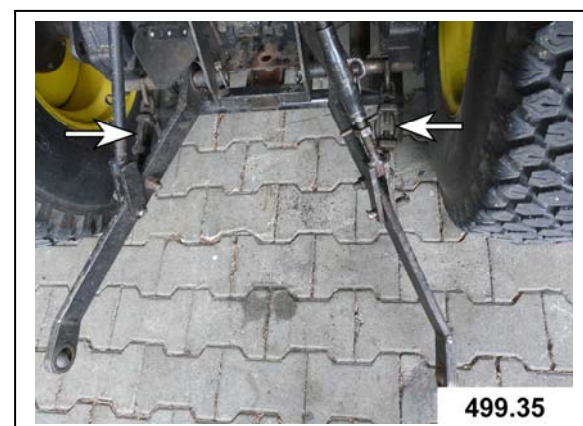
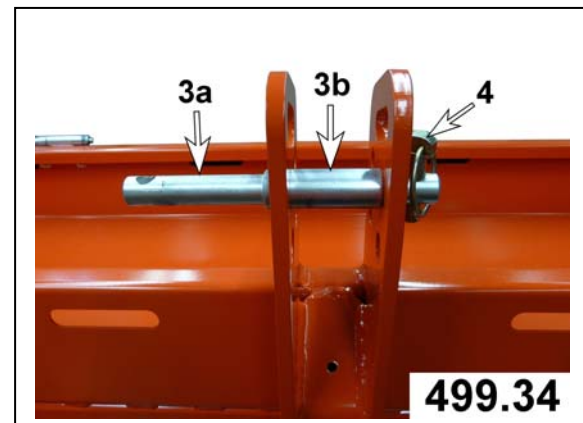
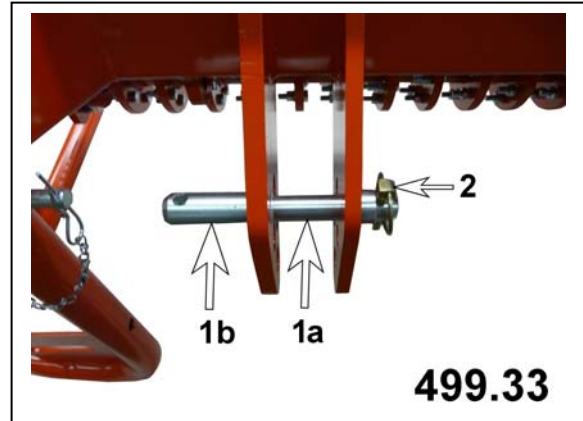

4.0. Connecting to the Tractor

4.4. Attachment to the tractor

For attachment note the following:

- a swinging drawbar or a yoke coupling.
- hydraulic connection at the rear of the tractor

For tractors that do not have this equipment, please contact your dealer.

Attach drawbar to tractor and lock.

The hydraulics are connected to the hydraulic connectors on the rear end of the tractor.

Avoid tight bends and chafing of the hydraulic lines.

Set hydraulic valve to open position.



4.5. Drawbar support

Machine support in top position, insert pin and lock.



5.0. Disconnecting from the Tractor

5.1. General

Only place the TERRA SLIT:

- on a firm, stable and smooth surface and
- with the machine supports fully lowered.

This ensures the security of the TERRA SLIT and prevents the tines from being damaged.

5.2. Unhitching TERRA SLIT

Park the TERRA SLIT on the machine supports only.

Lower machine supports to the bottom position and lock.

Lower Terra Slit to the ground.

Release top connecting rod and disconnect the installed machine.

Release the connecting rod clamps. Pull out bottom connecting rod pins.

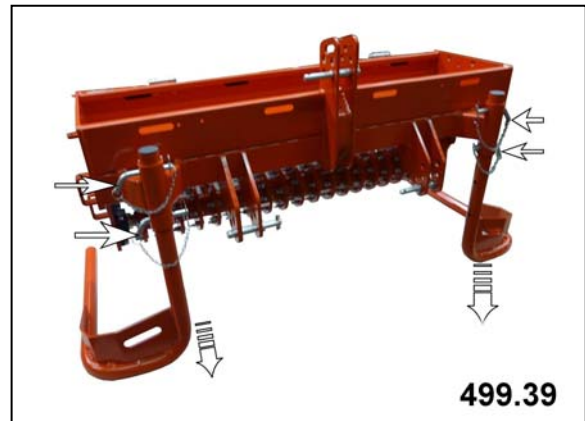

5.0. Disconnecting from the Tractor

5.3. Unhitch TERRA SLIT

Push the moving gear of the hitched machine down to the stop with the hydraulics.

Switch ball valve to "CLOSED" position to prevent the machine from lowering unexpectedly.

Release hydraulic pressure in the lines.



Lower stand on drawbar and lock with connector (A).

Disconnect hydraulic lines and attach to bracket (B).

Disconnect tractor from drawbar.

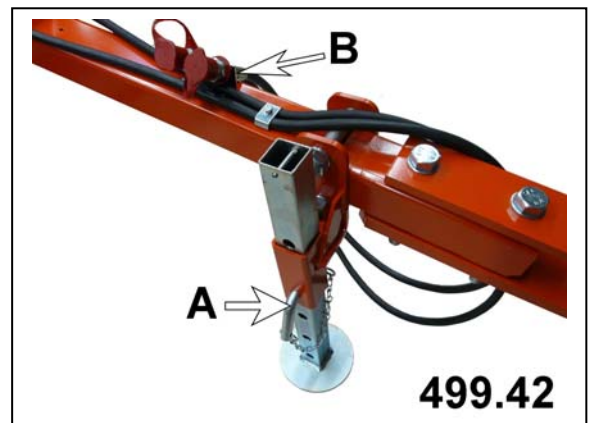

6.0. Before Using

6.1. General



ATTENTION DANGER !

It is important to become familiar with all devices and operating elements as well as their action before starting service to make sure that all safety equipment has been properly mounted. It will be too late for this during operation!

Observe the operating instructions and pay attention to general safety specifications and occupational health and safety regulations!

The equipment version with drawbar is **NOT** approved for operation on public roads.

Always ensure there is sufficient front-axle load; the steering capability of the vehicle must be maintained. (if needed, put on ballast weights, see operator's manual of tractor).

Special care should be taken when working and turning on a slope.

- RISK OF TIPPING OVER!

6.0. Before Using

6.2. Indicator and adjustment components

Ball valve on both hydraulic cylinders for locking the moving gear for transportation and maintenance work.

Position: "OPEN"



Position "CLOSED"



Top connecting rod from drawbar to frame of basic unit.

The horizontal position is set to working position with the top connecting rod.



6.0. Before Using

6.3. Adjusting TERRA SLIT

Lower Terra Slit in working position on a flat surface.

Adjust the top connecting rod so the top edge of the frame is parallel to the ground.

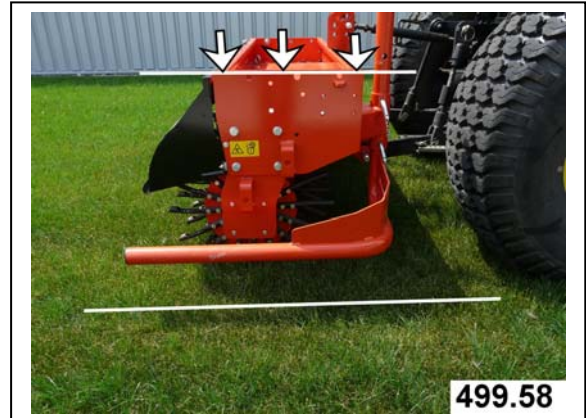

6.4. Adjusting rear roller

Note:

Adjust the rear roller with the tines only.

The working depth is adjusted with holes 1 to 4

Hole 1 for 2 in.

Hole 2 for 4 in.

Hole 3 for 5 in.

Hole 4 for 8 in.

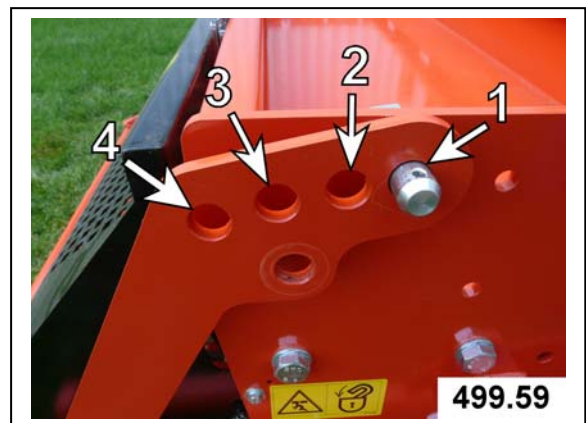

7.0. Operation

7.1. General



ATTENTION :

The operator of the TERRA SLIT is responsible for persons inside the working area.

Never operate the TERRA SLIT without its safety devices. If you do operate the TERRA SLIT without safety devices, you expose yourself and others to extreme danger.

Always check the immediate surroundings when starting to drive (be careful of CHILDREN!).

Do not drive backwards when the TERRA SLIT is operating. Avoid big changes in direction while using articulated tractors.

The equipment version with drawbar is **NOT** approved for operation on public roads.

With the equipment version with three-point frame, the tractor must always be in the floating position during operation.

7.0. Operation

7.2. Driving properties



CAUTION!

- The driving and operating characteristic of the tractor may be affected by installation of the TERRA SLIT.
- Always adapt your driving style to match the terrain and ground conditions.
- Special care should be taken when working and turning on a slope.
 - **RISK OF TIPPING OVER!**

Drive at a moderate speed for better results.

Do not turn sharply.

7.3. Working with the TERRA SLIT

NOTE:

Lower the attached TERRA SLIT only:

- on the work area

Procedure: three-point hitch version

1. Lower TERRA SLIT to the ground
2. Set rear tractor hydraulics for floating position

NOTE:

Lower the attached TERRA SLIT only:

- on the work area

Procedure: trailer version

1. Lower TERRA SLIT to the ground
2. Raise moving gear from the ground
3. Lock hydraulic ball valve to prevent the moving gear from lowering unexpectedly

7.0. Operation

7.4. Faults and remedies

Description	Cause	Remedy
Machine weaves from left to right	Ground is too dry or too compact	Weigh frame down with additional weight
		When adding ballast note the approved total weight
	Work area twice	
	Rocky subsurface	Reduce the working depth.
Desired working depth not achieved	Ground is too dry or too compact	Weigh frame down with additional weight
		When adding ballast note the approved total weight
		Work area twice
	Too many tines in use	Reduce the number of tines by half
	Hydraulic weight transfer incorrectly adjusted	Check adjustment and readjust if necessary
	Rear roller incorrectly set	
Intensive blades rip up the turf	Ground is too clayey or boggy	Rotate tines 180 degrees (see Chapter 2.2. Figure 499.65)
Tines break	Driving in curves during operation	Do not drive in curves
	Rocky subsurface	Reduce the working depth.

8.0 Maintenance

8.1. General



ATTENTION DANGER !

All work for maintenance, repair and disassembly must be done by qualified technicians only.

Only perform maintenance work when the TERRA SLIT is mounted. Switch off the tractor and secure it against unintentional starting.

For this work, please use your personal protective equipment (PSA) such as: gloves, goggles, ear protectors.

Use **original parts only**; parts from other manufacturers are often not of the required quality and therefore constitute safety hazards. Furthermore, the guarantee only retains its validity, and legitimate guarantee claims can only be recognized, if **original parts from Wiedenmann** have been used exclusively.

We would like to draw your attention, in particular, to the fact that original parts which are not supplied by Wiedenmann have neither been tested nor approved by Wiedenmann. The installation and / or employment of such products can, in some circumstances therefore, have negative structural effects on your vehicle and negatively affect active and / or passive safety. The manufacturer is in no way liable for damage resulting from the use of parts from other manufacturers.

After maintenance, remove all parts not belonging to the TERRA SLIT. Then mount the cover. (See chapter "Safety Equipment" 1.2.).

8.0 Maintenance

8.2. Maintenance and inspection list

Working hours	Check	Procedure
10	Flange bearing for loosening rotor	Lubricating
10	Pedestal bearing for rear roller	Lubricating

8.0 Maintenance

8.3. Lubrication

- Only perform maintenance work when the TERRA SLIT is mounted. Switch off the tractor and secure it against unintentional starting.
- Lubricate frequently as required. (Until all lubrication points are sufficiently lubricated).
- Clean lubrication nipple before use.
- Clean up leaking grease.
- Before starting the machine after a longer standstill, lubricate and maintain the entire machine.
- Keep all exposed machine parts, threaded spindles and guides slightly lubricated.

Points for manual lubrication

See pictures.

The pictures only show one of several similar subassemblies with lubrication points.

Flange bearing for loosening rotor

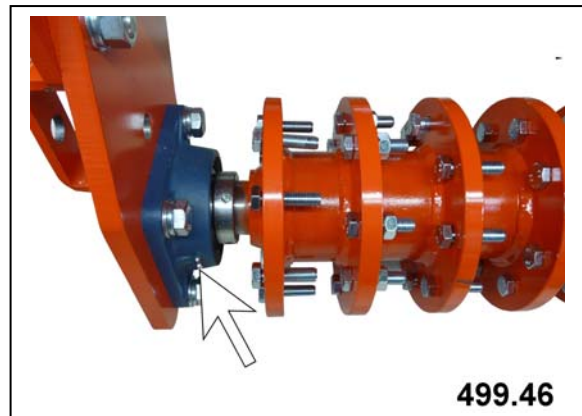

Pedestal bearing for rear roller



8.0 Maintenance

8.4. Cleaning TERRA SLIT

Clean the TERRA SLIT regularly.
You will prolong the service life
of expensive components and
simultaneously detect:

- Loose components
- Damaged wiring or
lines
- Wear and unintended collision
points.

NOTE:

Do not bring plastic and sealing
elements in contact with
aggressive liquids (e.g. carbon
tetrachloride, tri, benzene,
caustic solutions, acids etc.).
Soak up drops of oil with a
binding agent and dispose of
according to the regulations.
Eliminate the cause.
Only use wire brush and caustic
solutions in case of emergency.

Equipment and use
Cleaning with water

- All dirty parts, but use
caution:
⇒ water causes rust.

Cleaning with dry cloth

- All signs and labels

Cleaning with compressed air



ATTENTION !

Caution when using compressed
air. Put on safety glasses!
Without safety glasses you
risk eye injuries!
You also blow dirt into
the guides and bearings.
For this reason, avoid
this cleaning method as much
as possible.



8.0 Maintenance

8.5. Care and maintenance of the hydraulic system

Suitable for hydraulic fluids that are mineral, glycol and synthetic oil based.

Check hydraulic lines at regular intervals for damage and aging and replace if necessary.

The manufacturer's specified replacement interval for hydraulic lines is 6 years.



CAUTION !

The hydraulic system is not approved for the use of organic oils



CAUTION !

Escaping fluid under pressure can penetrate the skin causing serious injury. For this reason, always depressurize the system before disconnecting lines. Before pressure builds up again in the system, ensure that there are no leaks in any of the line connections. Hydraulic oil escaping from a small opening is hardly visible. A piece of cardboard should therefore be used when looking for leaks.

Protect hands and body from high pressure fluids.

If a fluid penetrates the skin, it must be removed immediately by a doctor who is familiar with such injuries; otherwise serious infections could result. Doctors unfamiliar with this type of injury should check a reliable medical reference.

8.0 Maintenance

8.6. Hydraulic connection diagram

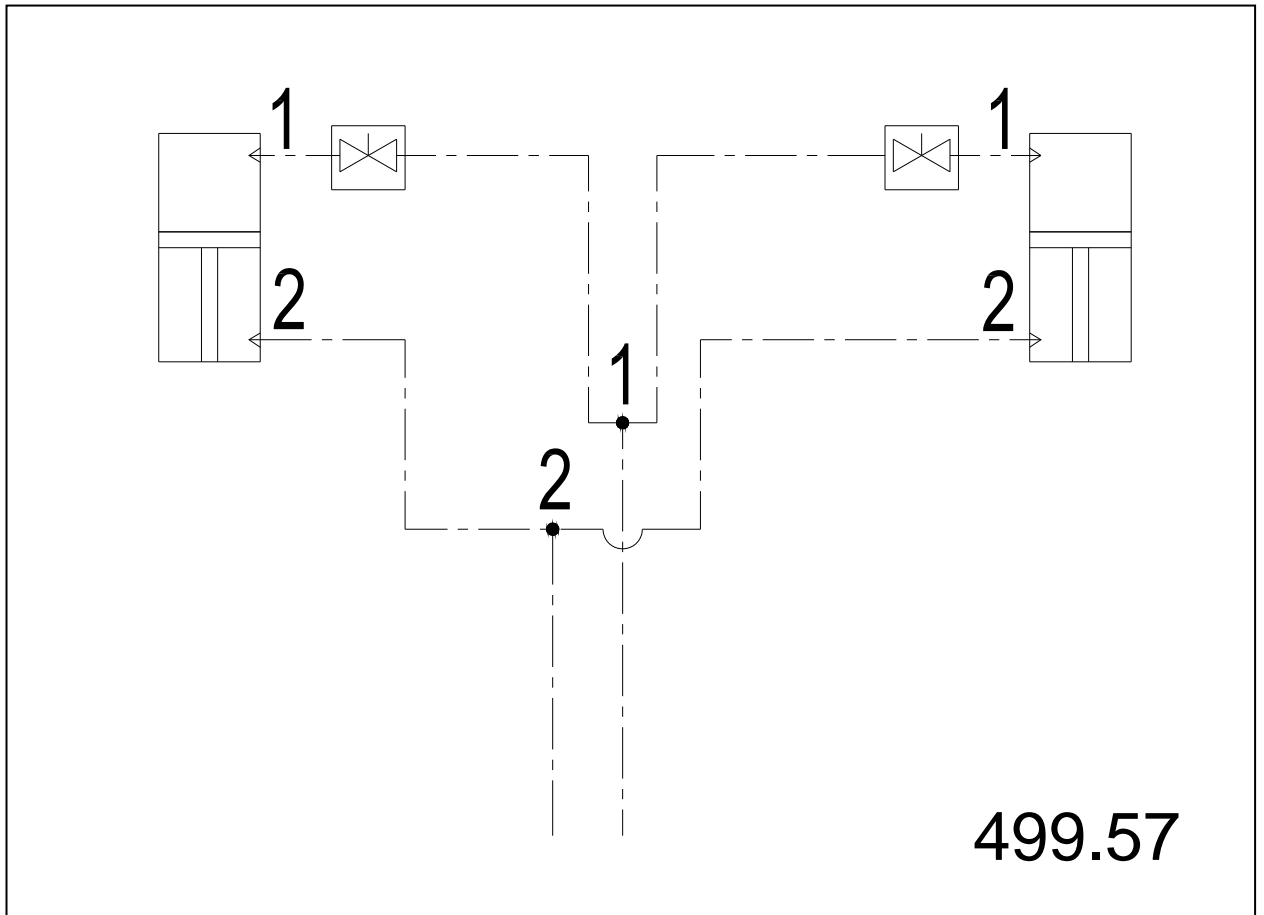

8.0 Maintenance

8.7. Wheels and tires

Check the tire pressure regularly: **250 kPa**



CAUTION:

If the tires burst and parts of the wheel rims fly off they may cause serious or fatal injury.

Install tires only if you have the necessary experience and equipment.

Always maintain the specified tire pressure. Never inflate tires above the recommended pressure. Do not heat wheels or tires or carry out welding work on them. Heating tires may cause them to burst because heating greatly increases the pressure in the tire. Welding may deform or damage a wheel.

When inflating a tire select a filler connection with a safety strap and an extension hose with sufficient length to allow the operator to stand clear of the tire during inflation. Never stand in front of or on the tire. Use a safety cage if available.

Check wheels and tires daily for low pressure, cuts, bulges, damaged rims, missing wheel studs or nuts.

8.0 Maintenance

8.8. Disassembly / Disposal



ATTENTION !

Take care when you dismount the TERRA SLIT.

Read the chapter "Safety and Precautions" and observe local safety regulations.

Danger points are:

- residual pressure in lines and adjusting elements,
- heavy parts might fall down after dismounting,
- sharp edges
- the machine might tilt and crush someone.

Disassembly / Disposal

1. Place the TERRA SLIT on stable ground.
2. Drain hydraulic oil.
3. Disassemble TERRA SLIT from the top downwards.

IMPORTANT :

Strictly observe the regulations and laws concerning the disposal of environmentally hazardous substances. Familiarize yourself completely with the procedure for disposal.

8.0 Maintenance

8.9. Unauthorized modification and spare part manufacturing

- Modifications of the TERRA SLIT are only authorized with the permission of the manufacturer!
- Original spare parts and accessories authorized by the manufacturer guarantee your safety. The use of other parts might change the characteristics of the TERRA SLIT. In this case we do not accept any liability.

9.0. Equipment

9.1. Equipment supplied

Basic unit

for three-point linkage

with a tine roller

Operating manual,
transfer declaration
with warranty card.

9.2. Approved machine combinations







Three-point version	1	2	3	4	5	6	7
Basic unit	S	S	S	S	S	S	S
Standard tines	W	W	W	W	W	W	W
Intensive tines	W	W	W	W	W	W	W
Fine-cut tines	W	W	W	W	W	W	W
Blades	W	W	W	W	W	W	W
Hollow-tine	W	W	W	W	W	W	W
Half-disk set	W	W	W	W	W	W	W
1 to 3 additional weights			O	O			O
Trailing roller					O	O	O
Hydraulic weight transfer		O		O		O	O

Trailer version	8	9	10	11			
Basic unit	S	S	S	S			
Standard tines	W	W	W	W			
Intensive tines	W	W	W	W			
Fine-cut tines	W	W	W	W			
Blades	W	W	W	W			
Hollow-tine	W	W	W	W			
Half-disk set	W	W	W	W			
Moving gear with drawbar	O	O	O	O			
1 to 3 additional weights		O		O			
Trailing roller			O	O			

S = Standard	W = Available	O = Option
---------------------	----------------------	-------------------

9.0. Equipment

9.3. Set of tines

 <p>423.48</p>	Standard tines	Number	Pitch 3 in.	Pitch 6 in.
		Max. working depth	8 in.	
		Tine rows per working width	19	10
 <p>423.49</p>	Intensive tines	Number	76	40
		Max. working depth	8 in.	
		Tine rows per working width	19	10
 <p>423.50</p>	Fine-cut tines	Number	76	40
		Max. working depth	6 in.	
		Tine rows per working width	19	10
 <p>499.14</p>	Half-disk set and	Number	- - -	10
	Hollow-tine	Number	- - -	80
		Max. working depth	3 in.	
		Holes per m ²	- - -	40
 <p>499.15</p>	Half-disk set and	Number	- - -	10
	Hollow-tine	Number	- - -	160
		Max. working depth	3 in.	
		Holes per m ²	- - -	80
 <p>499.60</p>	Half-disk set and	Number	19	10
	Blades	Number	152	80
		Max. working depth	4 in.	
		Tine rows per working width	19	10

9.0. Equipment

9.4. Optional equipment

TERRA SLIT	Three-point version	Trailer version
Standard tines	W	W
Intensive tines	W	W
Fine-cut tines	W	W
Blades	W	W
Hollow-tine	W	W
Half-disk set	W	W
One additional weight complete	O	O
Two additional weights complete	O	O
Three additional weights complete	O	O
Moving gear with drawbar	- - -	O
Trailing roller complete	O	O
Hydraulic weight transfer	O	O

10.0. Specifications

10.1.1. Technical details

Three-point version :

A	Machine length	in.	34
B	Machine length with trailing roller	in.	49
C	Machine width with machine supports	in.	77
D	Machine height in parking position	in.	41
E	Height to lower connecting rod connection, bottom	in.	18
F	Height to lower connecting rod connection, top	in.	22
G	Height up to middle of lower connecting rod connection	in.	36
H	Height up to middle of upper connecting rod connection	in.	38
J	Working width	in.	53
	Max. working depth	see Chapter 9.3.	
	Min. power required for tractor	HP (KW)	30 (22)
	Min. lifting power of tractor with standard fittings	lb.	2205
	Weights:		
	Basic unit with safety cover	lb.	622
	Basic unit without safety cover	lb.	586
	Standard tines 40 units for pitch 6 in.	lb.	106
	Standard tines 76 units for pitch 3 in.	lb.	203
	Intensive tines 40 units for pitch 6 in.	lb.	71
	Intensive tines 76 units for pitch 3 in.	lb.	134
	Fine-cut tines 40 units for pitch 6 in.	lb.	71
	Fine-cut tines 76 units for pitch 3 in.	lb.	134
	Blades 80 units for pitch 6 in.	lb.	123
	Blades 152 units for pitch 3 in.	lb.	234
	Hollow-tine 160 units for pitch 6 in.	lb.	101
	Half-disk set 10 units for pitch 6 in.	lb.	106
	Half-disk set 19 units for pitch 3 in.	lb.	201
	Wiedenmann additional weight.....1 unit	lb.	106
2 unit	lb.	212
3 unit	lb.	318
	Trailing roller	lb.	137
	Hydraulic weight transfer	lb.	75
	Approved additional weight in ballast frame	lb.	1102
	Approved total weight of TERRA SLIT	lb.	2205
	The noises are drowned out by the tractor engine.		

10.0. Specifications

10.1.1. Technical details

Three-point version :

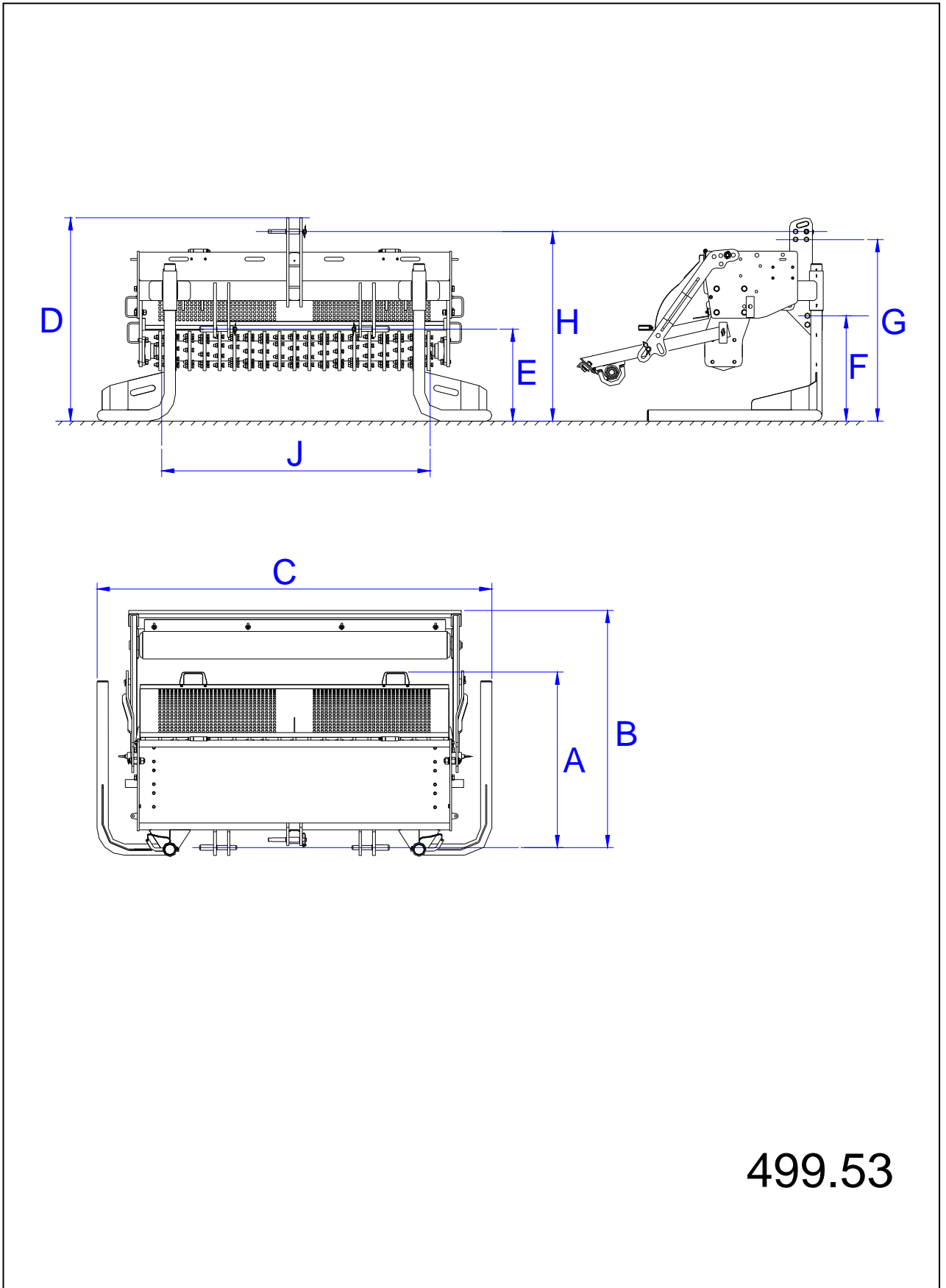

499.53

10.0. Specifications

10.1.2. Technical details

Trailer version :

A	Machine length	in.	88
B	Machine length with trailing roller	in.	98
C	Machine width	in.	96
D	Machine height in parking position	in.	43
E	Working width	in.	53
	Max. working depth	see Chapter 9.3.	
	Min. power required for tractor	HP(KW)	30 (22)
	Min. hydraulic operating pressure	psi	2031
	Max. hydraulic operating pressure	psi	2538
	Tires	18.8.50-8 / 6PR	
	Tire pressure	psi	36
F	Track width	in.	82
	Number of axles	pcs	2
	Number of wheels per axle	pcs	1
	Permissible drawbar load	lb.	419
	Weights:		
	Basic unit with safety cover	lb.	595
	Basic unit without safety cover	lb.	560
	Moving gear with drawbar	lb.	406
	Standard tines 40 units for pitch 6 in.	lb.	106
	Standard tines 76 units for pitch 3 in.	lb.	203
	Intensive tines 40 units for pitch 6 in.	lb.	71
	Intensive tines 76 units for pitch 3 in.	lb.	134
	Fine-cut tines 40 units for pitch 6 in.	lb.	71
	Fine-cut tines 76 units for pitch 3 in.	lb.	134
	Blades 80 units for pitch 6 in.	lb.	123
	Blades 152 units for pitch 3 in.	lb.	234
	Hollow-tine 160 units for pitch 6 in.	lb.	101
	Half-disk set 10 units for pitch 6 in.	lb.	106
	Half-disk set 19 units for pitch 3 in.	lb.	201
	Wiedenmann additional weight.....1 unit	lb.	106
2 unit	lb.	212
3 unit	lb.	318
	Trailing roller	lb.	137
	Approved additional weight in ballast frame	lb.	882
	Approved total weight of TERRA SLIT	lb.	2205
	The noises are drowned out by the tractor engine.		

10.0. Specifications

10.1.2. Technical details

Trailer version :

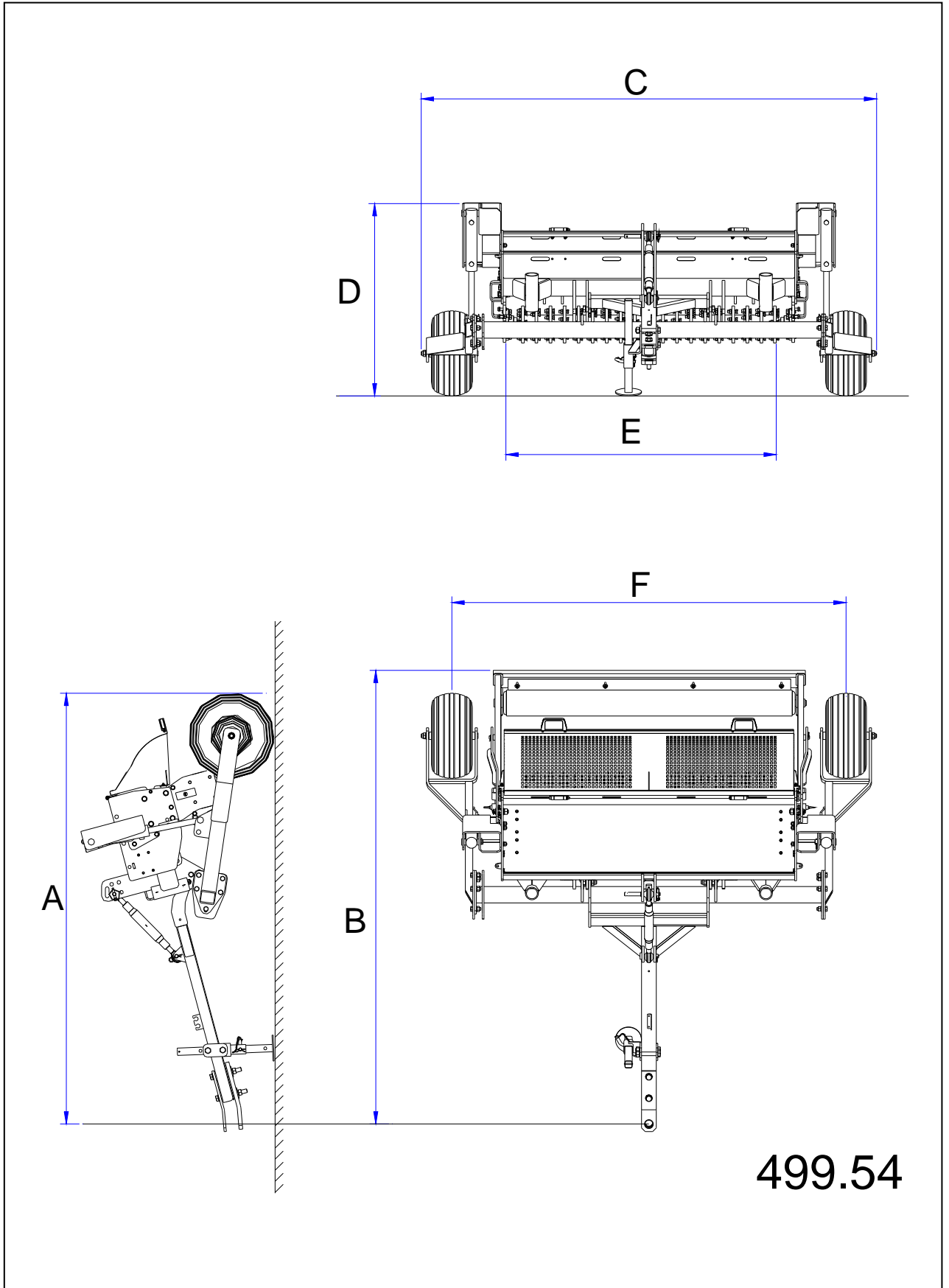

10.0. Specifications

10.2. Metric bolt and cap screw torque values

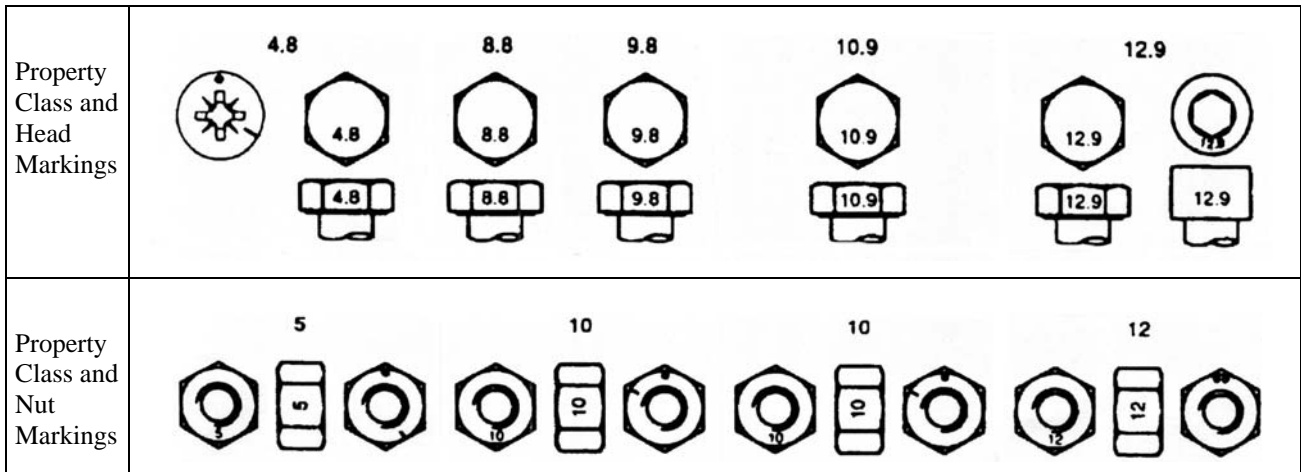

Size	class 4.8				class 8.8 or 9.8				class 10.9				class 12.9			
	Dry **		Lubricated *		Dry **		Lubricated *		Dry **		Lubricated *		Dry **		Lubricated *	
	N-m	lb-ft	N-m	lb-ft	N-m	lb-ft	N-m	lb-ft	N-m	lb-ft	N-m	lb-ft	N-m	lb-ft	N-m	lb-ft
M6	4,8	3,5	6	4,5	9	6,5	11	8,5	13	9,5	17	12	15	11,5	19	14,5
M8	12	8,5	15	11	22	16	28	20	32	24	40	30	37	28	47	35
M10	23	17	29	21	43	32	55	40	63	47	80	60	75	55	95	70

M12	40	29	50	37	75	55	95	70	110	80	140	105	130	95	165	120
M14	63	47	80	60	120	88	150	110	175	130	225	165	205	150	260	190
M16	100	73	125	92	190	140	240	175	275	200	350	255	320	240	400	300

M18	135	100	175	125	260	195	330	250	375	275	475	350	440	325	560	410
M20	190	140	240	180	375	275	475	350	530	400	675	500	625	460	800	580
M22	260	190	330	250	510	375	650	475	725	540	925	675	850	625	1075	800

M24	330	250	425	310	650	475	825	600	925	675	1150	850	1075	800	1350	1000
M27	490	360	625	450	950	700	1200	875	1350	1000	1700	1250	1600	1150	2000	1500
M30	675	490	850	625	1300	950	1650	1200	1850	1350	2300	1700	2150	1600	2700	2000

M33	900	675	1150	850	1750	1300	2200	1650	2500	1850	3150	2350	2900	2150	3700	2750
M36	1150	850	1450	1075	2250	1650	2850	2100	3200	2350	4050	3000	3750	2750	4750	3500

DO NOT use these values if a different torque value or tightening procedure is given for a specific application. Torque values listed are for general use only. Check tightness of fasteners periodically.

Shear bolts are designed to fail under predetermined loads. Always replace shear bolt with identical property class

Fasteners should be replaced with the same or higher property class. If higher property class

* "Lubricated" means coated with a lubricant such as engine oil, or fasteners with phosphate and oil coatings.

fasteners used, these should only be tightened to the strength of the original.

Make sure fastener threads are clean and that threads are properly engaged. This will prevent them from failing when tightening.

Tighten plastic insert or crimped steel-type lock nuts to approximately 50 percent of the dry torque shown in the chart, applied to the nut, not to the bolt head. Tighten toothed or serrated-type lock nuts to the full torque value.

** "Dry" means plain or zinc plated without any lubrication.

10.0. Specifications

10.3. Serial Number

Record product identification No. (serial no.) in the space provided below. Always quote this number when ordering spare parts or making warranty claims.

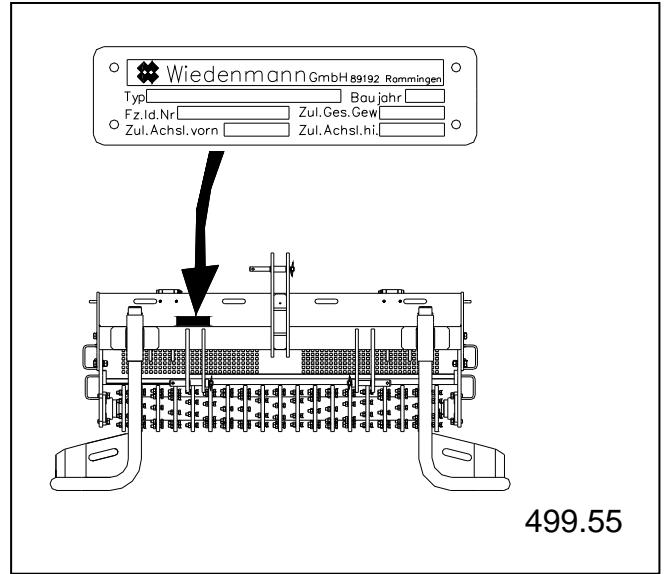

Product Identification Number:.....