



**Count on it.**

**Operator's Manual**

**Workman® HDX Utility Vehicle**

Model No. 07366—Serial No. 310000001 and Up

Model No. 07367—Serial No. 310000001 and Up

Model No. 07367TC—Serial No. 310000001 and Up

Model No. 07370—Serial No. 310000001 and Up

Model No. 07370TC—Serial No. 310000001 and Up

This machine is a utility vehicle intended to be used by professional, hired operators in commercial applications. It is primarily designed for the transport of implements used in such applications. This vehicle allows for the safe transport of an operator and one passenger in the identified seats. The bed of this vehicle is not suitable for any riders.

This product complies with all relevant European directives, for details please see the separate product specific Declaration of Conformity (DOC) sheet.

## WARNING

### CALIFORNIA Proposition 65 Warning

The engine exhaust from this product contains chemicals known to the state of California to cause cancer, birth defects, or other reproductive harm.

**Important:** The engine in this product is not equipped with a spark arrested muffler. It is a violation of California Public Resource code Section 4442 to use or operate this engine on any forest-covered, brush covered, or grass-covered land as defined in CPRC 4126. Other states or federal areas may have similar laws.

## Introduction

Read this information carefully to learn how to operate and maintain your product properly and to avoid injury and product damage. You are responsible for operating the product properly and safely.

You may contact Toro directly at [www.Toro.com](http://www.Toro.com) for product and accessory information, help finding a dealer, or to register your product.

Whenever you need service, genuine Toro parts, or additional information, contact an Authorized Service Dealer or Toro Customer Service and have the model and serial numbers of your product ready. Figure 1 identifies the location of the model and serial numbers on the product. Write the numbers in the space provided.

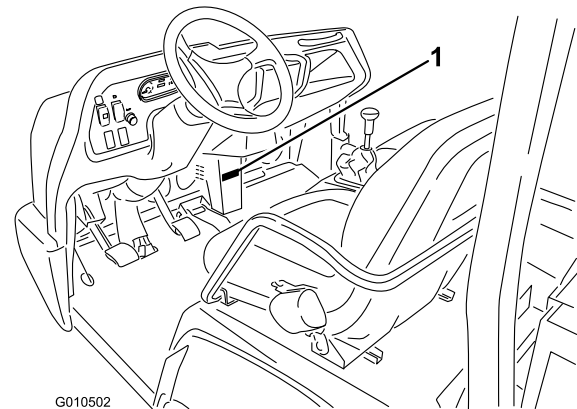

Figure 1

1. Model and serial number location

Model No. _____
Serial No. _____

This manual identifies potential hazards and has safety messages identified by the safety alert symbol (Figure 2), which signals a hazard that may cause serious injury or death if you do not follow the recommended precautions.



Figure 2

1. Safety alert symbol

This manual uses 2 other words to highlight information. **Important** calls attention to special mechanical information and **Note** emphasizes general information worthy of special attention.

# Contents

Introduction.....	2	Using The Differential Lock .....	30
Safety .....	4	Four Wheel Drive (Four Wheel Drive Models Only).....	31
Safe Operating Practices .....	4	Transporting Vehicle .....	31
Supervisor’s Responsibilities .....	5	Towing the Vehicle .....	31
Before Operating .....	5	Towing a Trailer with the Vehicle.....	32
Operation.....	5	Hydraulic Control.....	32
Maintenance.....	6	Maintenance.....	34
Sound Pressure.....	7	Recommended Maintenance Schedule(s) .....	34
Vibration.....	7	Service Interval Chart.....	35
Safety and Instructional Decals .....	8	Heavy Duty Operation .....	36
Setup .....	13	Premaintenance Procedures.....	36
1 Install the Steering Wheel(TC Models Only).....	13	Using the Bed Safety Support.....	36
2 Install the ROPS (Rollover Protection System)(TC Models Only) .....	13	Removing the Full Bed .....	37
3 Activate and Charge the Battery(TC Models Only).....	14	Installing the Full Bed.....	37
4 Checking Fluid Levels .....	15	Jacking the Vehicle.....	38
Product Overview .....	16	Removing the Hood .....	39
Controls .....	16	Lubrication.....	40
Specifications .....	20	Greasing Bearings and Bushings .....	40
Attachments/Accessories.....	20	Engine Maintenance.....	42
Operation.....	20	Inspecting the Carbon Canister Air Filter .....	42
Checking the Engine Oil Level.....	20	Servicing the Air Cleaner .....	42
Adding Fuel .....	21	Changing the Engine Oil And Filter .....	42
Checking the Cooling System.....	23	Replacing the Spark Plugs .....	43
Checking the Transaxle/Hydraulic Fluid Level.....	23	Fuel System Maintenance .....	44
Checking the High Flow Hydraulic Fluid (TC models only).....	23	Replacing the Fuel Filter .....	44
Checking the Front Differential Oil Level (Four Wheel Drive Models Only) .....	24	Fuel Lines and Connections .....	44
Checking the Torque of the Wheel Nuts.....	24	Electrical System Maintenance.....	45
Checking the Tire Pressure .....	25	Fuses.....	45
Checking the Brake Fluid.....	25	Jump Starting the Vehicle.....	45
Pre-starting Checks.....	25	Servicing the Battery.....	46
Starting the Engine.....	26	Drive System Maintenance .....	47
Driving the Vehicle.....	26	Changing the Front Differential Oil (Four Wheel Drive Models Only) .....	47
Stopping the Vehicle.....	26	Inspecting the Constant Velocity Boot (Four Wheel Drive Models Only) .....	47
Stopping the Engine.....	26	Adjusting the Shift Cables.....	47
New Vehicle Break-in .....	26	Adjusting the High-Low Cable .....	47
Checking the Interlock System.....	27	Adjusting Differential Lock Cable.....	47
Operating Characteristics .....	27	Inspecting the Tires .....	48
Passengers.....	28	Checking the Front Wheel Alignment .....	48
Speed .....	28	Cooling System Maintenance .....	49
Turning.....	29	Removing Debris from the Cooling System.....	49
Braking .....	29	Changing Engine Coolant.....	50
Tip Overs.....	29	Brake Maintenance .....	51
Hills .....	29	Adjusting the Parking Brake.....	51
Loading and Dumping.....	30	Adjusting the Brake Pedal .....	51
		Belt Maintenance.....	52
		Adjusting the Alternator Belt .....	52
		Controls System Maintenance.....	53
		Adjusting the Accelerator Pedal .....	53
		Adjusting the Clutch Pedal.....	53

# Safety

The machine meets the requirements of SAE J2258.

Supervisors, operators and service persons should be familiar with the following standards and publications: (The material may be obtained from the address shown).

- Flammable and Combustible Liquids Code:  
ANSI/NFPA 30
- National Fire Protection Association:  
ANSI/NFPA #505; Powered Industrial Trucks  
ADDRESS:  
National Fire Prevention Association  
Barrymarch Park  
Quincy, Massachusetts 02269 U.S.A
- ANSI/ASME B56.8 Personal Burden Carriers  
ADDRESS:  
American National Standards Institute, Inc.  
1430 Broadway  
New York, New York 10018 U.S.A.
- ANSI/UL 558; Internal Combustion Engine  
Powered Industrial Trucks  
ADDRESS:  
American National Standards Institute, Inc.  
1430 Broadway  
New York, New York 10018 U.S.A.  
or  
Underwriters Laboratories  
333 Pfingsten Road  
Northbrook, Illinois 60062 U.S.A.

## Safe Operating Practices

### **▲ WARNING**

**The Workman is an off-highway vehicle only, and is not designed, equipped, or manufactured for use on public streets, roads or highways.**

The Workman was designed and tested to offer safe service when operated and maintained properly. Although hazard control and accident prevention partially are dependent upon the design and configuration of the machine, these factors are also dependent upon the awareness, concern, and proper training of the personnel involved in the operation, maintenance and storage of the machine. Improper use or maintenance of the machine can result in injury or death.

Converting the Speedometer .....	54
Hydraulic System Maintenance .....	55
Changing the Hydraulic Fluid and Cleaning the Strainer.....	55
Replacing the Hydraulic Filter .....	55
Changing the High Flow Hydraulic Oil and Filter (TC Models only).....	56
Raising the Box in an Emergency .....	56
Storage.....	58
Schematics .....	60

This is a specialized utility vehicle designed for off-road use only. Its ride and handling will have a different feel than what drivers experience with passenger cars or trucks. So take time to become familiar with your Workman.

Not all of the attachments that adapt to the Workman are covered in this manual. See the specific *Operator's Manual* provided with each attachment for additional safety instructions. **Read these manuals.**

**To reduce the potential for injury or death, comply with the following safety instructions:**

## Supervisor's Responsibilities

- Make sure operators are thoroughly trained and familiar with the *Operator's Manual* and all labels on the vehicle.
- Be sure to establish your own special procedures and work rules for unusual operating conditions (e.g. slopes too steep for vehicle operation). Use the 3rd High Lockout switch if high speed could result in a safety or vehicle abuse situation.

## Before Operating

- Operate the machine only after reading and understanding the contents of this manual. A replacement manual is available by sending complete model and serial number to: The Toro® Company, 8111 Lyndale Avenue South, Minneapolis, Minnesota 55420.
- **Never** allow children to operate the vehicle. **Never** allow adults to operate it without proper instructions. Only trained and authorized persons should operate this vehicle. Make sure all operators are physically and mentally capable of operating the vehicle.
- This vehicle is designed to carry **only you**, the operator, and **one passenger** in the seat provided by the manufacturer. **Never** carry any other passengers on the vehicle.
- **Never** operate the vehicle when under the influence of drugs or alcohol.
- Become familiar with the controls and know how to stop the engine quickly.
- Keep all shields, safety devices and decals in place. If a shield, safety device or decal is malfunctioning, illegible, or damaged, repair or replace it before operating the machine.
- Always wear substantial shoes. Do not operate the machine while wearing sandals, tennis shoes, or sneakers. Do not wear loose fitting clothing or

jewelry which could get caught in moving parts and cause personal injury.

- Wearing safety glasses, safety shoes, long pants, and a helmet is advisable and required by some local safety and insurance regulations.
- Keep everyone, especially children and pets, away from the areas of operation.
- Before operating the vehicle, always check all parts of the vehicle and any attachments. If something is wrong, **stop using vehicle**. Make sure the problem is corrected before vehicle or attachment is operated again.
- Since gasoline is highly flammable, handle it carefully.
  - Use an approved fuel container.
  - Do not remove the cap from the fuel tank when the engine is hot or running.
  - Do not smoke while handling fuel.
  - Fill the fuel tank outdoors and to about one inch below the top of tank (bottom of filler neck). **Do not overfill.**
  - Wipe up any spilled fuel.
- Operate vehicle only outdoors or in a well ventilated area.
- Use only an approved nonmetal, portable fuel container. Static electric discharge can ignite fuel vapors in a ungrounded fuel container. Remove the fuel container from the bed of the vehicle and place it on the ground away from the vehicle before filling. Keep the nozzle in contact with the container while filling. Remove equipment from vehicle bed before filling.
- Check the safety interlock system daily for proper operation. If a switch should malfunction, replace the switch before operating machine.

## Operation

- The operator and passenger should use seat belts and remain seated whenever the vehicle is in motion. The operator should keep both hands on the steering wheel, whenever possible, and the passenger should use the hand holds provided. Keep arms and legs within the vehicle body at all times. Never carry passengers in the box or on attachments. Remember your passenger may not be expecting you to brake or turn and may not be ready.
- Never overload your vehicle. The name plate (located under the middle of the dash) shows the load limits

for the vehicle. Never overfill attachments or exceed the vehicle maximum gross vehicle weight (GVW).

- When starting the engine:
  - Sit on operator’s seat and ensure that the parking brake is engaged.
  - Disengage PTO (if so equipped) and return the hand throttle lever to the Off position (if so equipped).
  - Make sure the hydraulic lift lever is in the center position.
  - Move shift lever to Neutral and press the clutch pedal.
  - Keep your foot off of the accelerator pedal.
  - Turn the ignition key to the Start position.
- Using the machine demands attention. Failure to operate vehicle safely may result in an accident, tip over of the vehicle, and serious injury or death. Drive carefully. To prevent tipping or loss of control, take the following precautions:
  - Use extreme caution, reduce speed, and maintain a safe distance around sand traps, ditches, creeks, ramps, any unfamiliar areas, or other hazards.
  - Watch for holes or other hidden hazards.
  - Use caution when operating the vehicle on a steep slope. Normally, travel straight up and down slopes. Reduce speed when making sharp turns or when turning on hillsides. Avoid turning on hillsides whenever possible.
  - Use extra caution when operating the vehicle on wet surfaces, at higher speeds, or with a full load. Stopping time will increase with a full load. Shift into a lower gear before starting up or down a hill.
  - When loading the bed, distribute the load evenly. Use extra caution if the load exceeds the dimensions of the vehicle/bed. Operate the vehicle with extra caution when handling off-center loads that cannot be centered. Keep loads balanced and secure to prevent them from shifting.
  - Avoid sudden stops and starts. Do not go from reverse to forward or forward to reverse without first coming to a complete stop.
  - Do not attempt sharp turns or abrupt maneuvers or other unsafe driving actions that may cause a loss of vehicle control.
  - Do not pass another vehicle traveling in the same direction at intersections, blind spots, or at other dangerous locations.
  - When dumping, do not let anyone stand behind vehicle and do not dump the load on any one’s

feet. Release the tailgate latches from the side of box, not from behind.

- Keep all bystanders away. Before backing up, look to the rear and ensure that no one is behind the vehicle. Back up slowly.
- Watch out for traffic when near or crossing roads. Always yield the right of way to pedestrians and other vehicles. This vehicle is not designed for use on streets or highways. Always signal your turns or stop early enough so other persons know what you plan to do. Obey all traffic rules and regulations.
- Never operate the vehicle in or near an area where there is dust or fumes in the air which are explosive. The electrical and exhaust systems of the vehicle can produce sparks capable of igniting explosive materials.
- Always watch out for and avoid low overhangs such as tree limbs, door jambs, over head walkways, etc. Make sure there is enough room over head to easily clear the vehicle and your head.
- If ever unsure about safe operation, **stop work** and ask your supervisor.
- Do not touch engine, transaxle, radiator, muffler or muffler manifold while engine is running or soon after it has stopped because these areas may be hot enough to cause burns.
- If the machine ever vibrates abnormally, stop immediately, turn engine off, wait for all motion to stop and inspect for damage. Repair all damage before resuming operation.
- Before getting off the seat:
  - Stop movement of the machine.
  - Lower bed.
  - Shut engine off and wait for all movement to stop.
  - Set parking brake.
  - Remove key from ignition.
- Lightning can cause severe injury or death. If lightning is seen or thunder is heard in the area, do not operate the machine; seek shelter.

## Maintenance

- Before servicing or making adjustments to the machine, stop the engine, set the parking brake, and remove the key from ignition to prevent accidental starting of the engine.
- Never work under a raised bed without placing the bed safety support on the fully extended cylinder rod.

- Make sure all hydraulic line connectors are tight, and all hydraulic hoses and lines are in good condition before applying pressure to the system.
- Keep your body and hands away from pin hole leaks or nozzles that eject hydraulic fluid under high pressure. Use paper or cardboard, not hands, to search for leaks. Hydraulic fluid escaping under pressure can have sufficient force to penetrate skin and do serious damage. If fluid is injected into the skin it must be surgically removed within a few hours by a doctor familiar with this form of injury or gangrene may result.
- Before disconnecting or performing any work on the hydraulic system, all pressure in the system must be relieved by stopping the engine, cycling the dump valve from raise to lower and/or lowering box and attachments. Place the remote hydraulics lever in the float position. If the box must be in raised position, secure it with the safety support.
- To make sure the entire machine is in good condition, keep all nuts, bolts, and screws properly tightened.
- To reduce the potential fire hazard, keep the engine area free of excessive grease, grass, leaves, and accumulation of dirt.
- If the engine must be running to perform a maintenance adjustment, keep hands, feet, clothing, and any parts of the body away from the engine and any moving parts. Keep everyone away.
- Do not overspeed the engine by changing the governor settings. The maximum engine speed is 3650 RPM. To ensure safety and accuracy, have an Authorized Toro Distributor check the maximum engine speed with a tachometer.
- If major repairs are ever needed or assistance is required, contact an Authorized Toro Distributor.
- To be sure of optimum performance and safety, always purchase genuine Toro replacement parts and accessories. Replacement parts and accessories made by other manufacturers could be dangerous. Altering this vehicle in any manner may affect the vehicle's operation, performance, durability or its use may result in injury or death. Such use could void the product warranty of The Toro® Company.
- This vehicle should not be modified without The Toro® Company's authorization. Direct any inquiries to The Toro® Company, Commercial Division, Vehicle Engineering Dept., 8111 Lyndale Ave. So., Bloomington, Minnesota 55420-1196. USA

## Sound Pressure

This unit has a sound pressure level at the operator's ear of 75 dBA, which includes an Uncertainty Value (K) of 1 dBA.

The sound pressure level was determined according to the procedures outlined in EN ISO 11201.

## Vibration

### Hand-Arm

- Measured vibration level for right hand = 0.34 m/s<sup>2</sup>
- Measured vibration level for left hand = 0.43 m/s<sup>2</sup>
- Uncertainty Value (K) = 0.5 m/s<sup>2</sup>

Measured values were determined according to the procedures outlined in EN 1032.

### Whole Body

- Measured vibration level = 0.33 m/s<sup>2</sup>
- Uncertainty Value (K) = 0.5 m/s<sup>2</sup>

Measured values were determined according to the procedures outlined in EN 1032.

# Safety and Instructional Decals

Safety decals and instructions are easily visible to the operator and are located near any area of potential danger. Replace any decal that is damaged or lost.

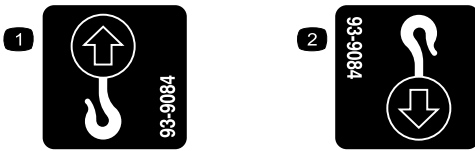

93-9084

1. Lift point
2. Tie-down point



106-6755

1. Engine coolant under pressure.
2. Explosion hazard—read the *Operator's Manual*.
3. Warning—do not touch the hot surface.
4. Warning—read the *Operator's Manual*.

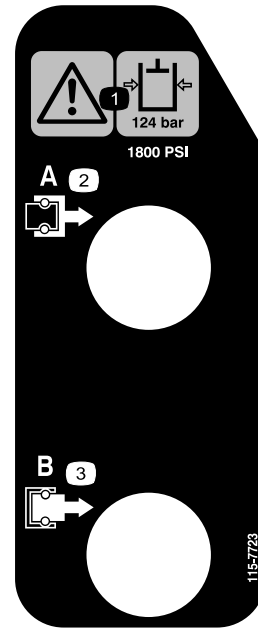

115-7723

1. Warning—the hydraulic oil pressure is 124 bar (1800 PSI).
2. Coupler A
3. Coupler B

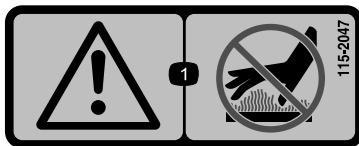

115-2047

1. Warning—do not touch the hot surface.

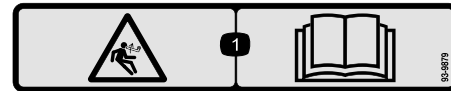

93-9879

1. Stored energy hazard—read the *Operator's Manual*.

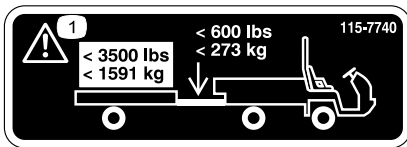

115-7740

1. Warning—maximum trailer weight is 1500 lb (680 kg), maximum tongue weight is 200 lb (90 kg).
2. Warning—trailer brakes are required when towing greater than 1500 lb (680 kg), maximum trailer weight with trailer brakes is 3500 lb (1591 kg), maximum tongue weight with trailer brakes is 600 lb (273 kg).



117-2718





115-7746

1. Warning—do not operate this machine unless you are trained.
2. Warning—lock the parking brake, stop the engine, and remove the ignition key before leaving the machine.
3. Fire hazard—stop the engine before fueling.
4. Tipping hazard—slow down and turn gradually, use caution and drive slowly when driving on slopes, do not exceed 20 mph (32 kph), and drive slowly over rough terrain or when carrying a full or heavy load.



115-2282

1. Warning—read the *Operator's Manual*.
2. Warning—stay away from moving parts, keep all guards and shields in place.
3. Crushing/dismemberment hazard of bystanders—keep bystanders a safe distance from the vehicle, do not carry passengers in the cargo bed, keep arms and legs inside of the vehicle at all times, and use seat belts and handholds.

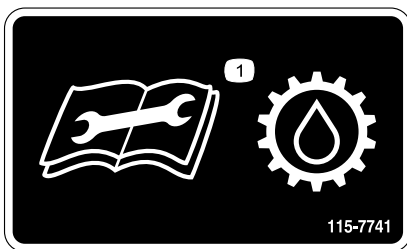

115-7741

1. Read the *Operator's Manual* before servicing transmission fluid.



105-4215

1. Warning—avoid pinch points.

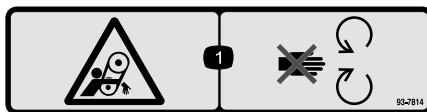

93-7814

1. Entanglement hazard, belt—stay away from moving parts.

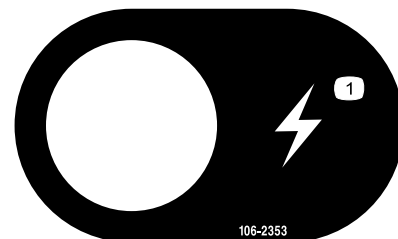

106-2353

1. Electrical power point

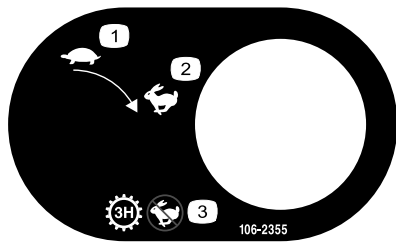

106-2355

1. Slow
2. Fast
3. Transmission—third high; no fast speed

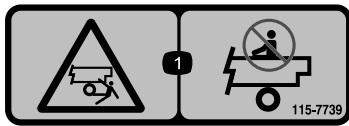

115-7739

1. Falling, crushing hazard, bystanders—no riders on machine.

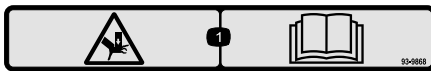

93-9868

1. Crushing hazard of hand—read the *Operator's Manual*.



**Battery Symbols**

Some or all of these symbols are on your battery

1. Explosion hazard
2. No fire, open flame, or smoking.
3. Caustic liquid/chemical burn hazard
4. Wear eye protection
5. Read the *Operator's Manual*.
6. Keep bystanders a safe distance from the battery.
7. Wear eye protection; explosive gases can cause blindness and other injuries
8. Battery acid can cause blindness or severe burns.
9. Flush eyes immediately with water and get medical help fast.
10. Contains lead; do not discard.



115-7756

1. High flow hydraulics—engaged

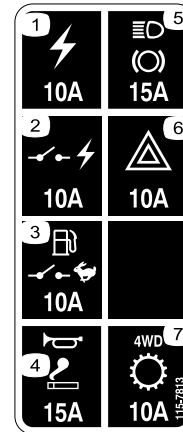

115-7813

1. Power outlet 10A
2. Switched power 10A
3. Fuel pump, supervisor switch 10A
4. Horn, power point 15A
5. Lights, brake 15A
6. Hazard 10A
7. 4WD, Transmission 10A



93-9850

1. Do not repair or revise—read the *Operator's Manual*.

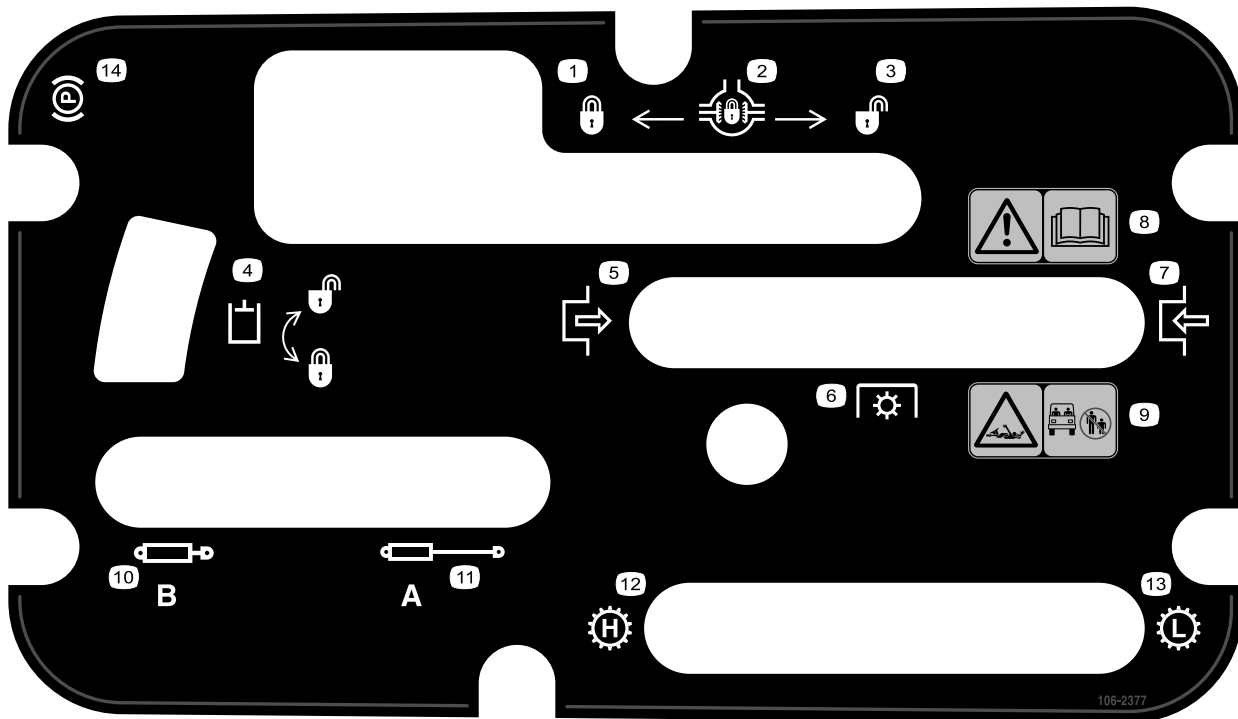

106-2377

1. Locked
2. Differential lock
3. Unlocked
4. Hydraulic lock
5. Engage
6. Power take-off (PTO)
7. Disengage
8. Warning—read the *Operator's Manual*.
9. Entanglement hazard, shaft—keep bystander's a safe distance from the vehicle.
10. Retract hydraulics
11. Extend hydraulics
12. Transmission—high speed
13. Transmission—low speed
14. Parking brake

## WORKMAN QUICK REFERENCE AID

### CHECK/SERVICE

1. ENGINE OIL DIP STICK
2. ENGINE OIL DRAIN
3. ENGINE OIL FILTER
4. ENGINE OIL FILL
5. HYDRAULIC OIL DIP STICK
6. HYDRAULIC OIL STRAINER
7. HYDRAULIC OIL FILTER
8. COOLANT FILL
9. FUEL
10. FUEL PUMP/FILTER (EFI ONLY)
11. FUEL FILTER/WATER SEPARATOR (AC GAS & DIESEL)
12. RADIATOR SCREEN
13. AIR FILTER (LCG & DIESEL)
14. AIR FILTER (AC GAS ONLY)
15. BATTERY
16. TIRE PRESSURE -  
32 PSI MAX FRONT, 18 PSI MAX REAR
17. 4WD SHAFT (4WD ONLY)
18. FRONT DIFFERENTIAL FILL (4WD ONLY)
19. BRAKE FLUID

☞ GREASE POINTS (100 HRS)

### FLUID SPECIFICATIONS/CHANGE INTERVALS

SEE OPERATOR'S MANUAL FOR INITIAL CHANGES	FLUID TYPE	CAPACITY		CHANGE INTERVALS	
		L	QT	FLUID	FILTER
ENGINE OIL LCG ONLY	SEE MANUAL	3.3	3.5	200 HRS.	200 HRS.
ENGINE OIL LCD ONLY		3.3	3.5	150 HRS.	150 HRS.
ENGINE OIL AC ONLY		1.9	2	100 HRS.	100 HRS.
TRANS/HYDRAULIC OIL	DEXRON III ATF	7.1	7.5	800 HRS.	800 HRS.
AIR CLEANER	CLEAN EVERY 50 HRS.				200 HRS.
FUEL	SEE MANUAL	24.6	6.5 GAL	---	400 HRS.
FUEL PUMP	---	---	---	---	400 HRS.
COOLANT 50/50 ETHYLENE GLYCOL WATER	---	3.5	3.7	1200 HRS.	---
TRANS AXLE STRAINER	---	CLEAN 800 HRS.			
DIFFERENTIAL OIL	MOBILE 424	0.25	0.26	800 HRS.	---

FOR HEAVY DUTY OPERATION, MAINTENANCE SHOULD BE PERFORMED TWICE AS FREQUENTLY.

115-7814

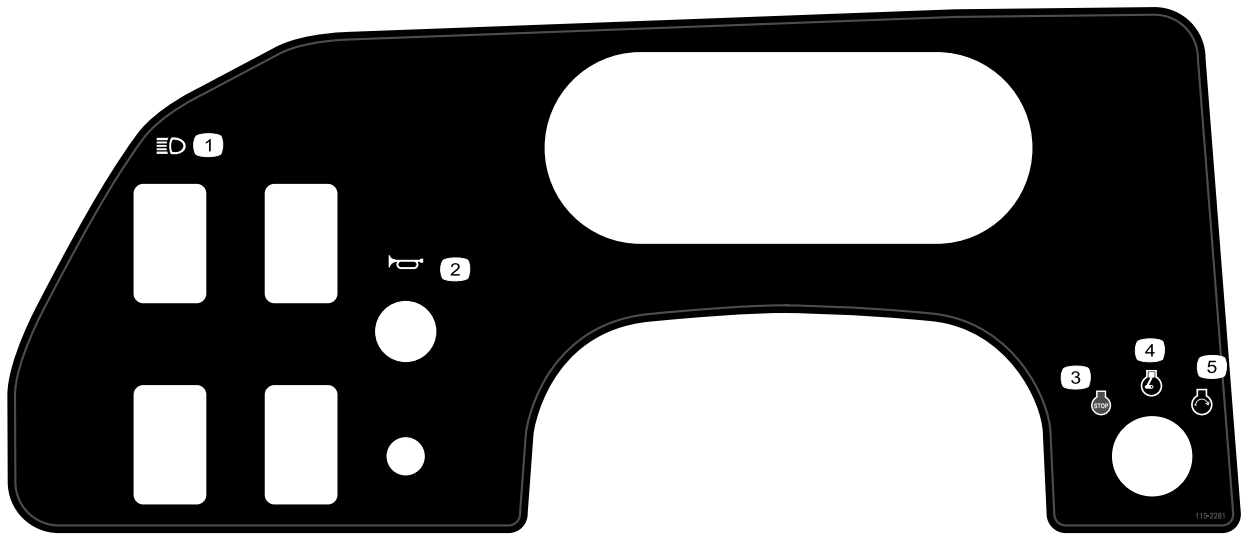

115-2281

- 1. Headlights
- 2. Horn
- 3. Engine—stop
- 4. Engine—run
- 5. Engine—start



106-7767

- 1. Warning—read the *Operator's Manual*; avoid tipping the machine; wear the seat belt; lean away from the direction the machine is tipping.

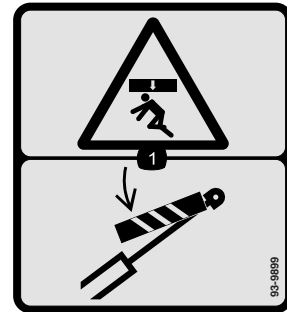

93-9899

- 1. Crushing hazard—install the cylinder lock.

# Setup

## Loose Parts

Use the chart below to verify that all parts have been shipped.

Procedure	Description	Qty.	Use
<b>1</b>	Steering wheel	1	Install the steering wheel.
	Cap	1	
	Washer	1	
<b>2</b>	ROPS frame	1	Mount the ROPS (Rollover Protection System)
	Bolt, 1/2 inch	6	
<b>3</b>	Electrolyte	A/R	Activate and charge the battery.
<b>4</b>	No parts required	–	Check the engine oil, transaxle/hydraulic fluid, and brake fluid levels

## Media and Additional Parts

Description	Qty.	Use
Operator's Manual	1	Read before operating the vehicle
Parts Manual	1	Use to reference part numbers
Operator Training Material	1	View before operating machine

**Note:** Determine the left and right side of the machine from the normal operating position.



## Install the Steering Wheel (TC Models Only)

### Parts needed for this procedure:

1	Steering wheel
1	Cap
1	Washer

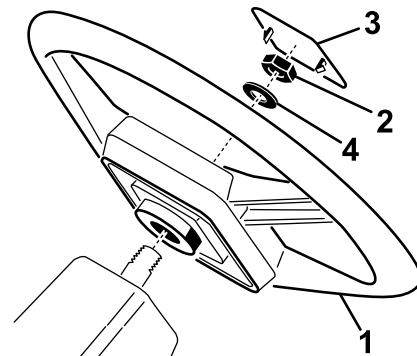

**Figure 3**

- |                   |           |
|-------------------|-----------|
| 1. Steering wheel | 3. Cap    |
| 2. Nut            | 4. Washer |

## Procedure

1. Remove the nut from the steering shaft. Slide the steering wheel and washer onto the steering shaft (Figure 3).
2. Secure the steering wheel to the shaft with the nut and tighten it to 20-25 ft-lb (27-34 N-m).
3. Install the cap on the steering wheel.

# 2

## Install the ROPS (Rollover Protection System) (TC Models Only)

### Parts needed for this procedure:

1	ROPS frame
6	Bolt, 1/2 inch

### Procedure

1. Align each side of the ROPS with the mounting holes on each side of vehicle frame as shown in Figure 4.
2. Secure each side of the ROPS to frame with 3 bolts (1/2 inch) and tighten then to 85 ft-lb (115 N-m).

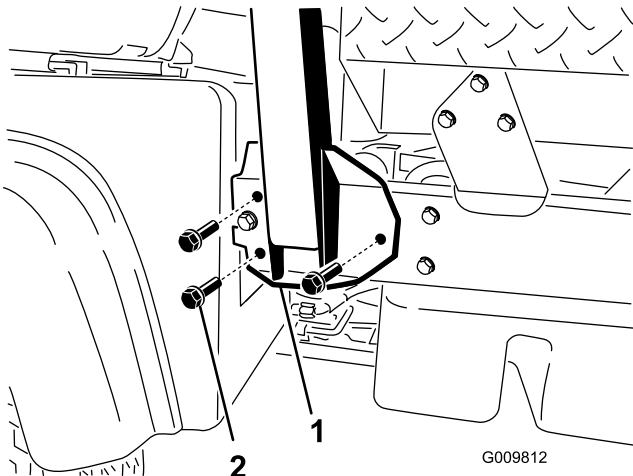

Figure 4

1. ROPS
2. Mounting bracket

# 3

## Activate and Charge the Battery (TC Models Only)

### Parts needed for this procedure:

A/R	Electrolyte
-----	-------------

### Procedure

If the battery is not filled with electrolyte or activated, it must be removed from the vehicle, filled with electrolyte and charged. Bulk electrolyte with 1.260 specific gravity can be purchased from a local battery supply outlet.

### WARNING

#### CALIFORNIA

#### Proposition 65 Warning

Battery posts, terminals, and related accessories contain lead and lead compounds, chemicals known to the State of California to cause cancer and reproductive harm.  
Wash hands after handling.

### ⚠ DANGER

Battery electrolyte contains sulfuric acid which is a deadly poison and causes severe burns.

- Do not drink electrolyte and avoid contact with skin, eyes or clothing. Wear safety glasses to shield your eyes and rubber gloves to protect your hands.
- Fill the battery where clean water is always available for flushing the skin.

1. Remove the battery cover from the battery case (Figure 5).

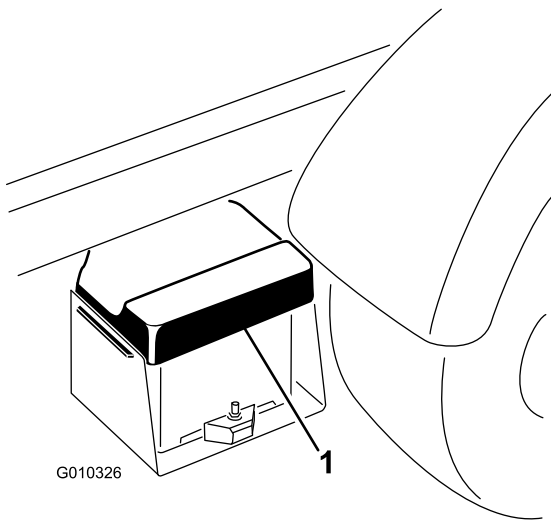

**Figure 5**

1. Battery cover

2. Remove the battery from the battery case.
3. Remove the filler caps from the battery and slowly fill each cell until electrolyte is just above the plates.
4. Replace the filler caps and connect a 3 to 4 amp battery charger to the battery posts. Charge the battery at a rate of 3 to 4 amperes for 4 to 8 hours.

### **⚠ WARNING**

**Charging the battery produces gasses that can explode.**

**Never smoke near the battery and keep sparks and flames away from battery.**

5. When the battery is charged, disconnect the charger from the electrical outlet and battery posts (Figure 6).

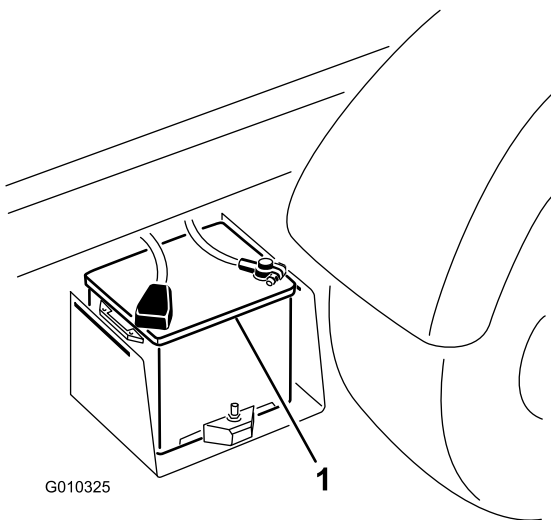

**Figure 6**

1. Battery

6. Remove the filler caps. Slowly add electrolyte to each cell until level is up to the fill ring. Install the filler caps.

**Important: Do not overfill the battery. Electrolyte will overflow onto other parts of the vehicle and severe corrosion and deterioration will result.**

7. Insert the battery into the battery case so the battery terminals are toward the outside of the vehicle.
8. Install the positive cable (red) to the positive (+) terminal and the negative cable (black) to the negative (-) terminal of the battery and secure them with bolts and nuts. Slide the rubber boot over the positive terminal to prevent a possible short-out from occurring.

### **⚠ WARNING**

**Incorrect battery cable routing could damage the machine and cables causing sparks. Sparks can cause the battery gasses to explode, resulting in personal injury.**

- Always disconnect the negative (black) battery cable before disconnecting the positive (red) cable.
- Always connect the positive (red) battery cable

9. Install the battery cover on the battery case.



## **Checking Fluid Levels**

### **No Parts Required**

### **Procedure**

1. Check the engine oil level before and after the engine is first started, refer to Checking the Engine Oil Level in Operation.
2. Check the transaxle/hydraulic fluid level before the engine is first started, refer to Checking the Transaxle/Hydraulic Fluid Level in Operation.
3. Check the brake fluid level before the engine is first started, refer to Checking the Brake Fluid Level in Operation.

# Product Overview

## Controls

**Note:** Determine the left and right sides of the machine from the normal operating position.

### Accelerator Pedal

The accelerator pedal (Figure 7) gives the operator the ability to vary the engine and ground speed of the vehicle, when the transmission is in gear. Pressing the pedal increases engine RPM and ground speed. Releasing the pedal will decrease engine RPM and ground speed of the machine.

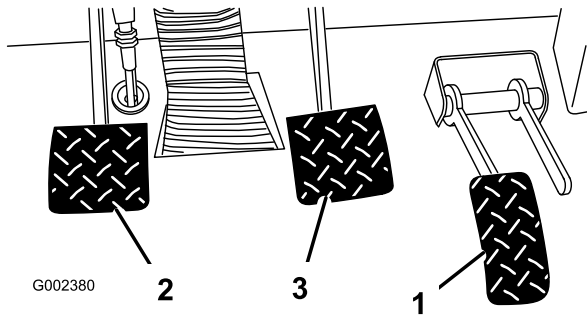

Figure 7

1. Accelerator pedal
2. Clutch pedal
3. Brake pedal

### Clutch Pedal

The clutch pedal (Figure 7) must be fully pressed to disengage clutch when starting the engine or shifting transmission gears. Release the pedal smoothly when the transmission is in gear to prevent unnecessary wear on the transmission and other related parts.

**Important:** Do not ride the clutch pedal during operation. The clutch pedal must be fully out or the clutch will slip causing heat and wear. Never hold the vehicle stopped on a hill using the clutch pedal. Damage to the clutch may occur.

### Brake Pedal

The brake pedal (Figure 7) is used to apply service brakes to stop or slow vehicle.

#### ⚠ CAUTION

Worn or maladjusted brakes may result in personal injury. If the brake pedal travels to within 1-1/2 inches (3.8 cm) of the vehicle floor board, the brakes must be adjusted or repaired.

## Gear Shift Lever

Fully press the clutch pedal and move the shift lever (Figure 7) into the desired gear selection. A diagram of the shift pattern is indicated in Figure 8.

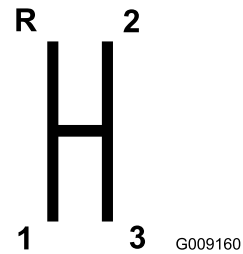

Figure 8

**Important:** Do not shift the transaxle to the reverse or forward gear unless the vehicle is standing still. Damage to the transaxle may occur.

#### ⚠ CAUTION

Down shifting from too high a speed can cause the rear wheels to skid resulting in loss of vehicle control as well as clutch and/or transmission damage. Shift smoothly to avoid grinding gears.

### Differential Lock

The differential lock allows rear axle to be locked for increased traction. The differential lock (Figure 9) may be engaged when the vehicle is in motion. Move the lever forward and to the right to engage the lock.

**Note:** Vehicle motion plus a slight turn is required to engage or disengage differential lock.

#### ⚠ CAUTION

Turning with the differential lock on can result in loss of vehicle control. Do not operate with differential lock on when making sharp turns or at high speeds. Refer to using the differential lock.



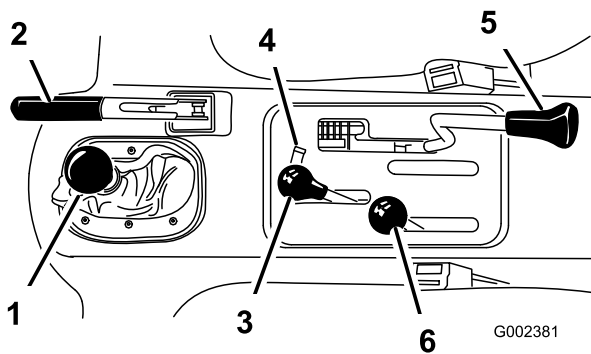

**Figure 9**

- |                       |                           |
|-----------------------|---------------------------|
| 1. Gear shift lever   | 4. Hydraulic lift lock    |
| 2. Parking brake      | 5. Differential lock      |
| 3. Hydraulic bed lift | 6. High–low range shifter |

## Parking Brake

Whenever the engine is shut off, the parking brake (Figure 9) must be engaged to prevent accidental movement of the vehicle. To engage the parking brake, pull back on the lever. To disengage, push the lever forward. Release the parking brake before moving the vehicle. If you park the vehicle on a steep grade, apply the parking. Also, shift the transmission into 1st gear on an uphill grade or reverse on a down hill grade. Place chocks at the down hill side of the wheels.

## Hydraulic Lift

The hydraulic lift raises and lowers bed. Move it rearward to raise the bed, and forward to lower it (Figure 9).

**Important:** When lowering the bed, hold the lever in the forward position for 1 or 2 seconds after the bed contacts the frame to secure it in the lowered position. Do not hold the hydraulic lift in either the raise or lower position, for more than 5 seconds, once the cylinders have reached the end of their travel.

## Hydraulic Lift Lock

The hydraulic lift lock locks the lift lever so the hydraulic cylinders do not operate when the vehicle is not equipped with a bed (Figure 9). It also locks the lift lever in the On position when using the hydraulics for attachments.

## High–Low Range Shifter

The high–low range shifter adds three additional speeds for precise speed control (Figure 9).

- The vehicle must be completely stopped before shifting between High and Low range.

- Shift only on level ground.
- Press clutch pedal fully.
- Move the lever fully forward for High and fully rearward for Low.

High is for higher speed driving on level, dry surfaces with light loads.

Low is for low speed driving. Use this range when greater than normal power or control is required. For example, steep grades, difficult terrain, heavy loads, slow speed but high engine speed (spraying).

**Important:** There is a location between High and Low in which the transaxle is in neither range. Do not use this position as a neutral position because the vehicle could move unexpectedly if the High–Low shifter is bumped and the gear shift lever is in gear.

## Ignition Switch

Use the ignition switch (Figure 10) to start and stop the engine. It has three positions: Off, Run, and Start. Rotate the key clockwise to the Start position to engage the starter motor. Release the key when the engine starts. The key will move automatically to the On position. To shut the engine off, rotate the key counterclockwise to the Off position.

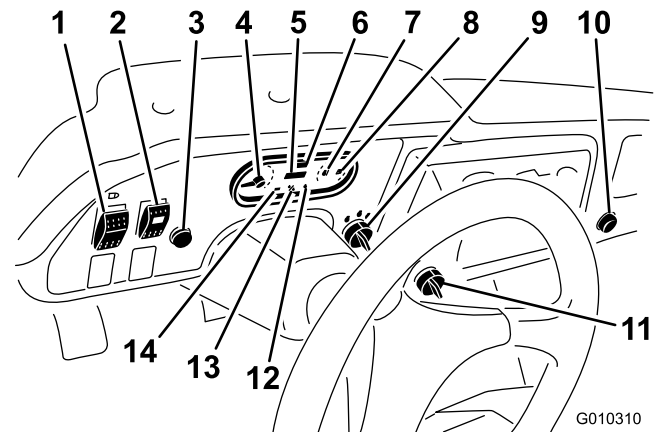

**Figure 10**

- |   |                                |
|---|--------------------------------|
| 1. Light switch                                 | 8. Fuel gauge                  |
| 2. High flow hydraulics switch (TC models only) | 9. Ignition switch             |
| 3. Horn (TC models only)                        | 10. Power point                |
| 4. Tachometer                                   | 11. 3rd high lockout switch    |
| 5. Speedometer                                  | 12. Oil pressure warning light |
| 6. Hour meter                                   | 13. Check engine light         |
| 7. Coolant temperature gauge and light          | 14. Charge indicator           |

## Hour Meter

Indicates the total hours of machine operation. The hour meter (Figure 10) starts to function whenever the key switch is rotated to the On position or if the engine is running.

## 3rd High Lockout Switch

Move the 3rd high lockout switch (Figure 10) to the slow position and remove the key to prevent the use of third gear when in the High range. The engine will shut off if the shift lever is moved to third gear when in High range. The key is removable in either position.

## Light Switch

Push the light switch (Figure 10) to toggle the headlights on or off.

## Oil Pressure Warning Light

The oil pressure warning light glows (Figure 10) if the engine oil pressure drops below a safe level while the engine is running. If the light flickers or remains on, stop the vehicle, turn off the engine, and check the oil level. If the oil level was low, but adding oil does not cause the light to go out when the engine is restarted, turn the engine off immediately and contact your local Toro distributor for assistance.

Check the operation of warning lights as follows:

1. Apply the parking brake.
2. Turn the ignition key to the On position, but do not start the engine. The oil pressure light should glow red. If the light does not function, either a bulb is burned out or there is a malfunction in the system which must be repaired.

**Note:** If engine was just turned off, it may take 1 to 2 minutes for the light to come on.

## Coolant Temperature Gauge and Light

Registers the coolant temperature in the engine. Operates only when the ignition switch is in On position (Figure 10). The indicator light will illuminate blinking red if the engine overheats.

## Charge Indicator

Illuminates when battery is being discharged. If light illuminates during operation, stop vehicle, turn off engine and check for possible causes, such as alternator belt (Figure 10).

**Important:** If alternator belt is loose or broken, do not operate the vehicle until adjustment or repair is complete. Failure to observe this precaution may result in damage to the engine.

Check the operation of warning lights as follows:

- Apply parking brake.
- Turn the ignition key to the On position, but do not start the engine. The coolant temperature, charge indicator, and oil pressure lights should glow. If any light does not function, either a bulb is burned out or there is a malfunction in the system which must be repaired.

## Fuel Gauge

The fuel gauge shows the amount of fuel in the tank. It operates only when ignition switch is in the On position (Figure 10). Red indicates low fuel level and blinking red indicates near empty.

## High Flow Hydraulics Switch (TC models only)

Turn on the switch to activate the high flow hydraulics (Figure 10).

## Horn Button (TC models only)

Pressing the horn button activates the horn (Figure 10).

## Tachometer

Registers the RPM of the engine (Figure 10 & Figure 11). White triangle indicates desired RPM for PTO operation (Figure 11).

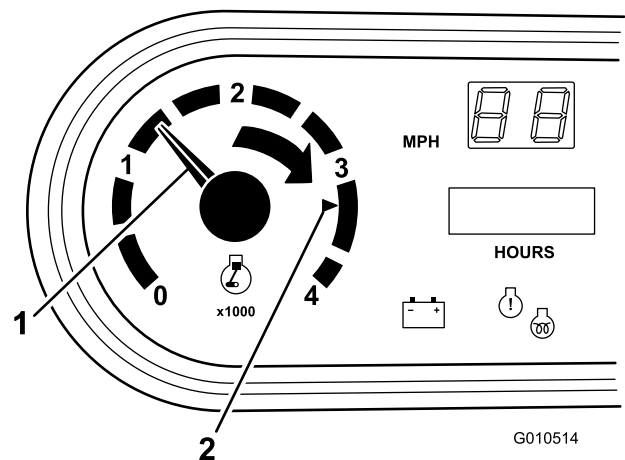

Figure 11

1. RPM of the engine
2. 3300 RPM for 540 RPM PTO operation

## Check Engine Light

The light (Figure 10) will illuminate to notify operator of a engine malfunction.

**Important:** The engine is equipped with on board diagnostics to trouble shoot engine malfunctions. Refer to the Toro Service Manual for information on the operation of the diagnostics and how to read the codes of the system.

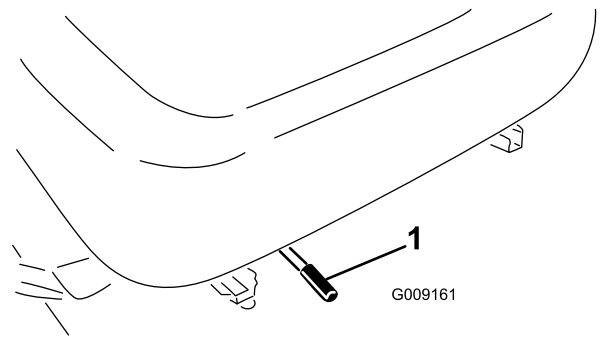

**Figure 13**

1. Seat adjusting lever
- 

## Speedometer

Registers the ground speed of the vehicle (Figure 10). The speedometer is in MPH but can easily converted to KPH. Refer to Converting the Speedometer in Controls Maintenance.

## Power Point

Use the power point (Figure 10) to power optional 12 volt electrical accessories.

## Passenger Hand Hold

The passenger hand hold is located on the dashboard (Figure 12).

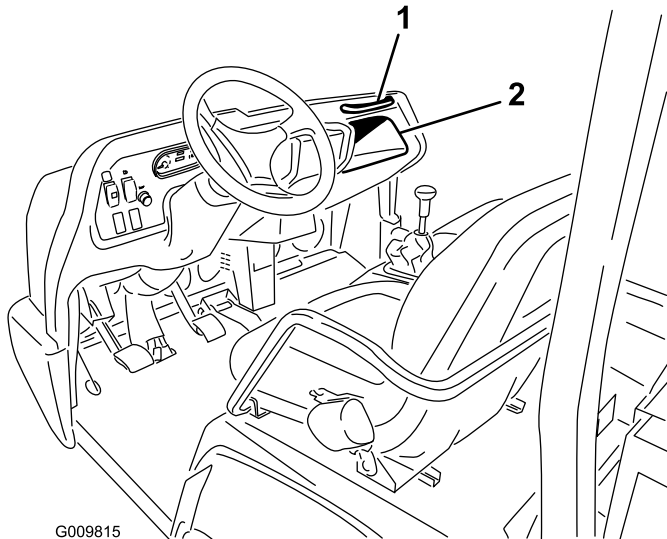

**Figure 12**

1. Passenger hand hold
  2. Storage compartment
- 

## Seat Adjusting Lever

The seats can be adjusted fore and aft for operator comfort (Figure 13).

# Specifications

**Note:** Specifications and design are subject to change without notice.

## Dimensions

Overall Width	63 inches (160 cm)
Overall Length	w/o bed: 128.25 inches (326 cm) w/full bed: 130.38 inches (331 cm) w/2/3 bed in rear mounting location: 136.38 inches (346 cm)
Base Weight (Dry)	Model 07366—1623 lb (736 kg) Model 07367—1951 lb (885 kg) Model 07367TC—2032 lb (921.6 kg) Model 07370—2010 lb (912 kg) Model 07370TC—2091 lb (948 kg)
Rated Capacity (includes 200 lb. operator, 200 lb. passenger and loaded attachment).	Model 07366—3227 lb (1464 kg) Model 07367—2899 lb (1315 kg) Model 07367TC—2818 lb (1278 kg) Model 07370—2840 lb (1288 kg) Model 07370TC—2759 lb (1251 kg)
Maximum Gross Vehicle Weight	4,850 lb (2200 kg)
Tow Capacity	Tongue weight 600 lb (272 kg) Maximum trailer weight 3,500 lb (1587 kg)
Ground Clearance	7 inches (18 cm) w/ no load
Wheel Base	70 inches (118 cm)
Wheel Tread (center line to center line)	Front: 46 inches (117 cm) Rear: 47.7 inches (121 cm)
Height	75 inches (190.5 cm) to top of ROPS

## Attachments/Accessories

A selection of Toro approved attachments and accessories are available for use with the machine to enhance and expand its capabilities. Contact your Authorized Service Dealer or Distributor or go to [www.Toro.com](http://www.Toro.com) for a list of all approved attachments and accessories.

# Operation

**Note:** Determine the left and right sides of the machine from the normal operating position.

## ⚠ CAUTION

**Before servicing or making adjustments to the machine, stop the engine, set the parking brake, and remove the key from the switch. Remove any load material from the bed or other attachment before working under a raised bed. Never work under a raised bed without positioning the safety support on a fully extended cylinder rod.**

## Checking the Engine Oil Level

**Service Interval:** Before each use or daily

The engine is shipped with approximately 3.5 quarts (3.3 l) (w/ filter) of oil in the crankcase; however, you should check the oil level before and after the engine is first started.

**Note:** The best time to check the engine oil is when the engine is cool before it has been started for the day. If it has already been run, allow the oil to drain back down to the sump for at least 10 minutes before checking. If the oil level is at or below the Add mark on the dipstick, add oil to bring the oil level to the Full mark. **Do not overfill.** If the oil level is between the Full and Add marks, no additional oil is required.

The engine uses any high-quality 10W-30 detergent oil having the American Petroleum Institute (API) service classification SJ, SK, SL, SM, or higher. Choose a viscosity according to the table in Figure 14.

### USE THESE SAE VISCOSITY OILS

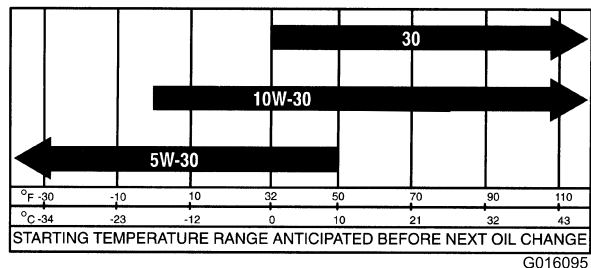

**Figure 14**

1. Position the machine on a level surface.
2. Remove the dipstick (Figure 15) and wipe it with a clean rag. Insert the dipstick into the tube and make sure it is seated fully. Remove dipstick and check the level of the oil.

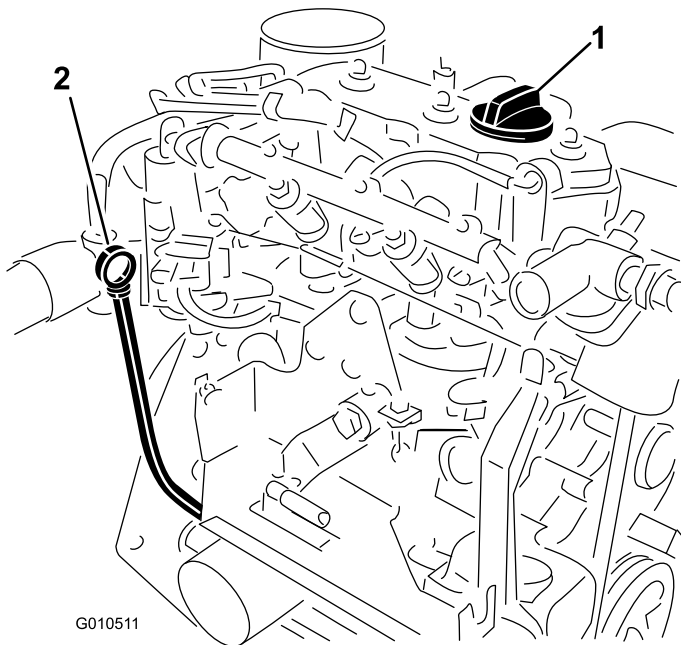

**Figure 15**

1. Filler cap
2. Dipstick

3. If the oil level is low, remove the filler cap (Figure 15) and add enough oil to raise the level to the Full mark on the dipstick.

**Note:** When adding oil, remove dipstick to allow proper venting. Pour oil slowly and check the level often during this process. **Do not overfill.**

**Important:** When adding engine oil or filling oil, there must be clearance between the oil fill device and the oil fill hole in the valve cover as shown in Figure 16. This clearance is necessary to permit venting when filling, which prevents oil from overrunning into the breather.

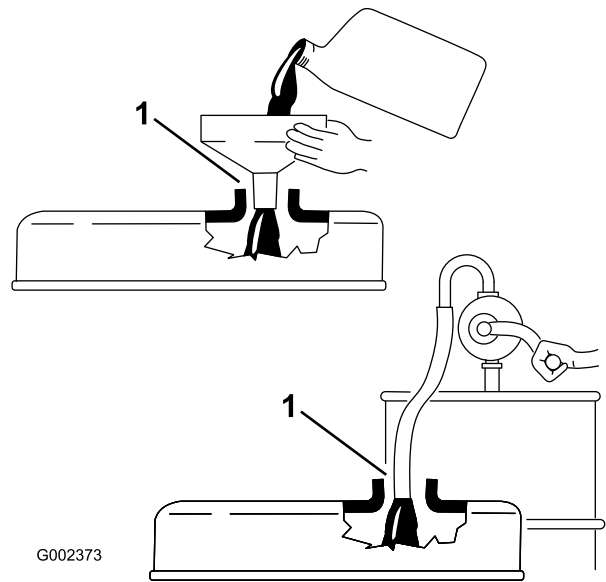

**Figure 16**

1. Note clearance

4. Install the dipstick firmly in place.

## Adding Fuel

The Toro® Company strongly recommends the use of fresh, clean, unleaded regular grade gasoline in Toro gasoline powered products. Unleaded gasoline burns cleaner, extends engine life, and promotes good starting by reducing the build-up of combustion chamber deposits. Use a minimum octane rating of 87.

Fuel tank capacity: 6.5 US gallons (25 l).

**Note:** Never use methanol, leaded gasoline, gasoline containing methanol, gasoline containing more than 10% ethanol, gasoline additives, or white gas because engine fuel system damage could result.

## **⚠ DANGER**

In certain conditions, gasoline is extremely flammable and highly explosive. A fire or explosion from gasoline can burn you and others and can damage property.

- Before removing the fuel tank cap, make sure the vehicle is positioned on a level surface. Open fuel tank cap slowly.
- Fill the fuel tank outdoors, in an open area, when the engine is cold. Wipe up any gasoline that spills.
- Never fill the fuel tank inside an enclosed trailer.
- Do not fill the fuel tank completely full. Add gasoline to the fuel tank until the level is 1 inch (25 mm) below the bottom of the filler neck. This empty space in the tank allows gasoline to expand.
- Never smoke when handling gasoline, and stay away from an open flame or where gasoline fumes may be ignited by a spark.
- Store gasoline in an approved container and keep it out of the reach of children. Never buy more than a 30-day supply of gasoline.
- Do not operate without entire exhaust system in place and in proper working condition.

## **⚠ DANGER**

In certain conditions during fueling, static electricity can be released causing a spark which can ignite the gasoline vapors. A fire or explosion from gasoline can burn you and others and can damage property.

- Always place gasoline containers on the ground away from your vehicle before filling.
- Do not fill gasoline containers inside a vehicle or on a truck or trailer bed because interior carpets or plastic truck bed liners may insulate the container and slow the loss of any static charge.
- When practical, remove gas-powered equipment from the truck or trailer and refuel the equipment with its wheels on the ground.
- If this is not possible, then refuel such equipment on a truck or trailer from a portable container, rather than from a gasoline dispenser nozzle.
- If a gasoline dispenser nozzle must be used, keep the nozzle in contact with the rim of the fuel tank or container opening at all times until fueling is complete.

1. Clean the area around the fuel tank cap.
2. Remove the fuel tank cap (Figure 17).

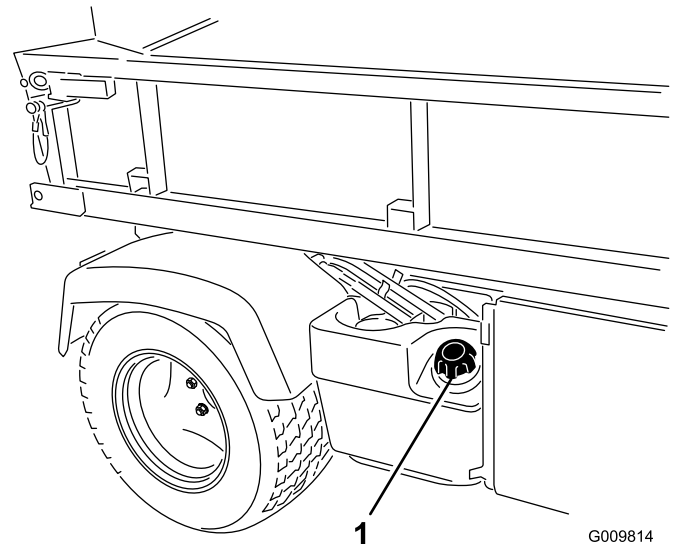

**Figure 17**

1. Fuel tank cap
3. Fill the tank to about one inch below the top of the tank, (bottom of the filler neck), then install the cap. **Do not overfill.**
4. Wipe up any fuel that may have spilled to prevent a fire hazard.

# Checking the Cooling System

**Service Interval:** Before each use or daily

**Cooling system capacity:** 4 qt (3.7 l)

The cooling system is filled with a 50/50 solution of water and permanent ethylene glycol antifreeze.

1. Park the machine on a level surface.

## ⚠ CAUTION

If the engine has been running, the pressurized, hot coolant can escape and cause burns.

- Do not open the radiator cap when the engine is running.
  - Allow the engine to cool at least 15 minutes or until the radiator cap is cool enough to touch without burning your hand.
  - Use a rag when opening the radiator cap, and open the cap slowly to allow steam to escape.
2. Check the coolant level on the side of the reserve tank (Figure 18). The coolant should be up to the Cold line, when engine is cold.

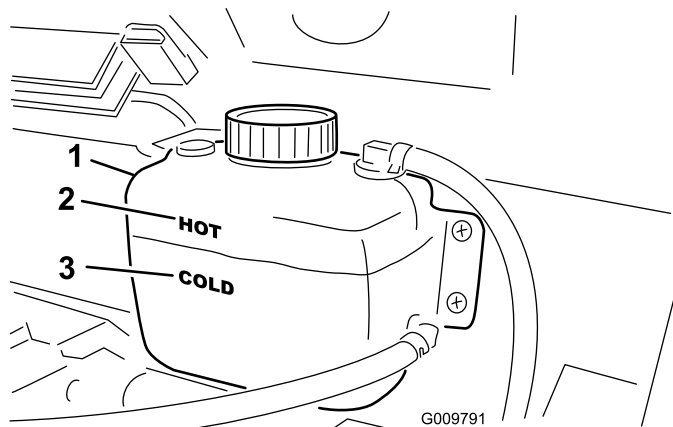

Figure 18

1. Reserve tank
2. Hot line
3. Cold line

3. If coolant is low, remove the reserve tank cap and add a 50/50 mixture of water and permanent ethylene glycol antifreeze. **Do not overfill.**
4. Install the reserve tank cap.

# Checking the Transaxle/Hydraulic Fluid Level

**Service Interval:** Before each use or daily

The transaxle reservoir is filled with Dexron III ATF. Check the level before the engine is first started and every 8 hours or daily, thereafter. Capacity of system is .

**Transaxle reservoir capacity:** 7.5 qt (7 l).

1. Position the vehicle on a level surface.
2. Clean the area around the dipstick (Figure 19).

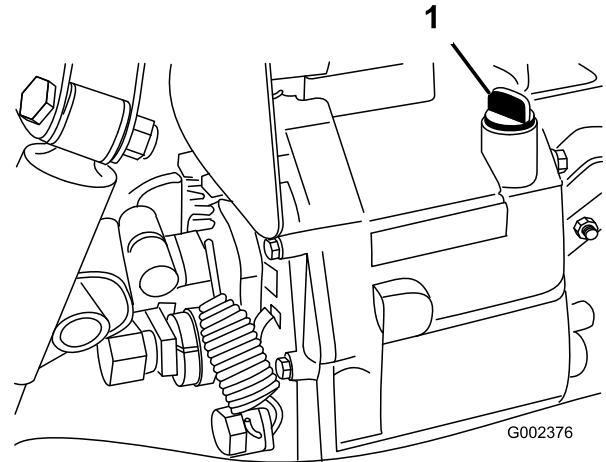

Figure 19

1. Dipstick
3. Unscrew the dipstick from the top of the transaxle and wipe it with a clean rag.
4. Screw the dipstick into the transaxle and ensure that it is fully seated.
5. Unscrew the dipstick and check the fluid level.  
The fluid should be up to top of the flat portion of the dipstick.
6. If the level is low, add enough fluid to achieve the proper level.

# Checking the High Flow Hydraulic Fluid (TC models only)

**Service Interval:** Before each use or daily

The high flow hydraulics reservoir is filled with approximately 4 US gallons (15 l) of high quality hydraulic fluid. **Check the level of hydraulic fluid before the engine is first started and daily thereafter.**

1. Clean the area around the filler neck and the cap of the hydraulic tank (Figure 20). Remove the cap from the filler neck.

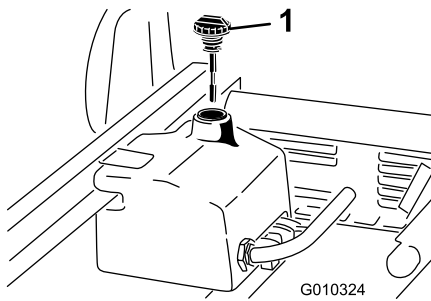

**Figure 20**

1. Cap
- 
2. Remove the dipstick (Figure 20) from the filler neck and wipe it with a clean rag. Insert the dipstick into the filler neck; then remove it and check the fluid level. The fluid level should be between the two marks on the dipstick.
  3. If the level is low, add the appropriate fluid to raise the level to the upper mark. Refer to Changing the High Flow Hydraulic Fluid.
  4. Install the dipstick and cap onto the filler neck.
  5. Start the engine and turn on the attachment. Let them run for about two minutes to purge air from the system. Stop the engine and attachment and check for leaks.

**Important:** The vehicle must be running before starting the high flow hydraulics.

### **▲ WARNING**

Hydraulic fluid escaping under pressure can penetrate skin and cause injury.

- Make sure all hydraulic fluid hoses and lines are in good condition and all hydraulic connections and fittings are tight before applying pressure to the hydraulic system.
- Keep your body and hands away from pin hole leaks or nozzles that eject high pressure hydraulic fluid.
- Use cardboard or paper to find hydraulic leaks.
- Safely relieve all pressure in the hydraulic system before performing any work on the hydraulic system.
- Seek immediate medical attention if fluid is injected into your skin.

## Checking the Front Differential Oil Level (Four Wheel Drive Models Only)

**Service Interval:** Every 100 hours/Monthly (whichever comes first)

The differential is filled with Mobil 424 hydraulic oil.

1. Position the vehicle on a level surface.
2. Clean the area around the fill/check plug on side of the differential (Figure 21).

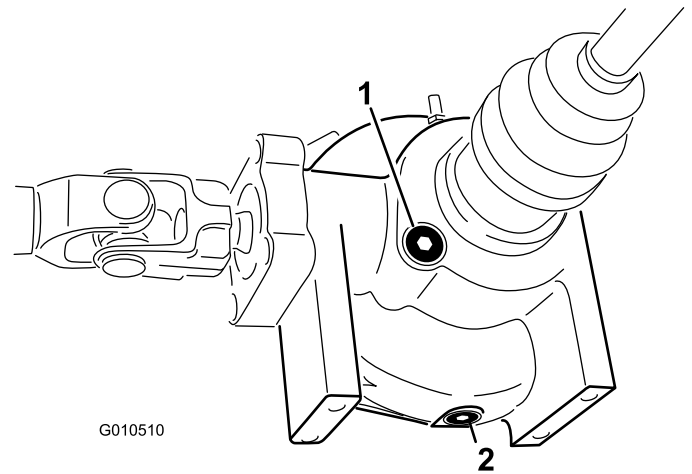

**Figure 21**

1. Fill/check plug
2. Drain plug

3. Remove the fill/check plug and check the level of the oil. The oil should be up to hole. If the oil is low, add Mobil 424 hydraulic oil.
4. Install the fill/check plug.

## Checking the Torque of the Wheel Nuts

**Service Interval:** After the first 2 hours

After the first 10 hours

Every 200 hours

### **▲ WARNING**

Failure to maintain proper torque of the wheel nuts could result in failure or loss of a wheel and may result in personal injury.

Torque the front and rear wheel nuts to 80 to 90 ft-lb (109 to 122 N-m) after 1 to 4 hours of operation and again after 10 hours of operation. Torque every 200 hours thereafter.



# Checking the Tire Pressure

**Service Interval:** Before each use or daily

The maximum air pressure in the front tires is 32 psi (220 kPa) and the rear tires is 18 psi (124 kPa).

Check the tire pressure frequently to ensure proper inflation. If the tires are not inflated to the correct pressure, the tires will wear prematurely.

Figure 22 is an example of tire wear caused by under inflation.

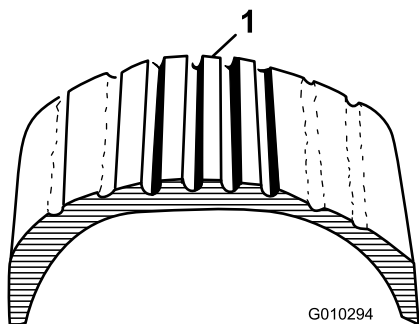

**Figure 22**

1. Under inflated tire

Figure 23 is an example of tire wear caused by over inflation.

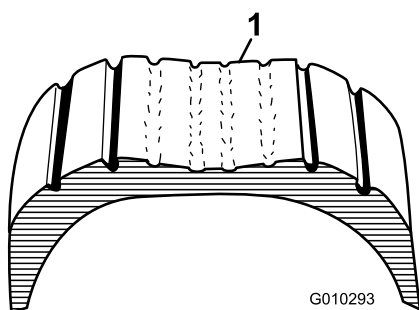

**Figure 23**

1. Over inflated tire

# Checking the Brake Fluid

**Service Interval:** Before each use or daily—Check the brake fluid level.

Every 1,000 hours/Every 2 years (whichever comes first)—Change the brake fluid.

The brake fluid reservoir is shipped from the factory filled with DOT 3 brake fluid. Check the level before the engine is first started and every 8 hours or daily, thereafter.

The brake fluid reservoir is located under the dash.

1. Park the machine on a level surface.
2. The fluid level should be up to the Full line on the reservoir (Figure 24).

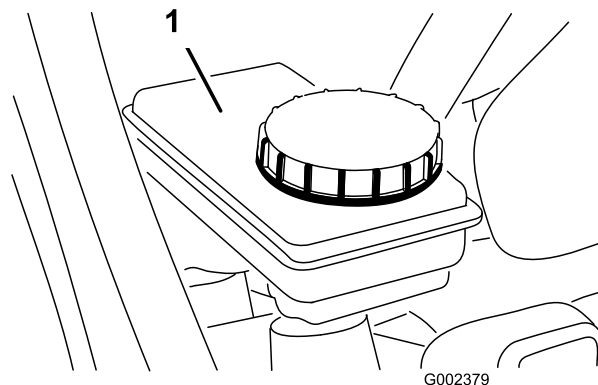
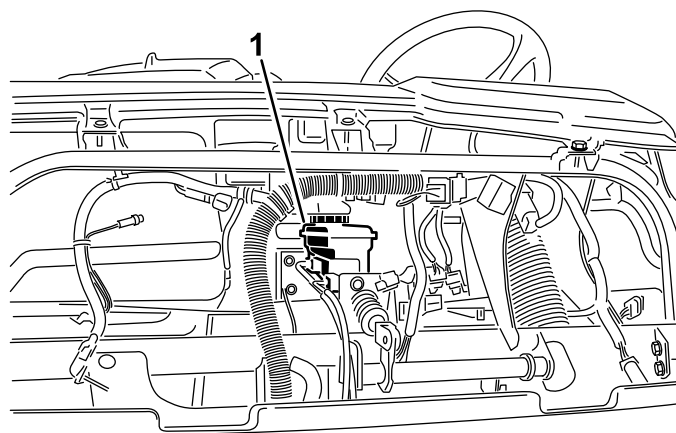

**Figure 24**

1. Brake fluid reservoir

3. If the fluid level is low, clean the area around the cap, remove the reservoir cap, and fill the reservoir to the proper level. **Do not overfill.**

**Note:** You can remove the hood access to the reservoir from the front of the machine (Figure 25).



**WORKMAN**

**Figure 25**

1. Brake fluid reservoir

# Pre-starting Checks

Safe operation begins before taking the vehicle out for a day's work. You should check these items each time:

- Check the tire pressure.

**Note:** These tires are different than car tires, they require less pressure to minimize turf compaction and damage.

- Check all fluid levels and add the appropriate amount of Toro specified fluids, if any are found to be low.
- Check the front of the radiator. Remove any debris and clean the radiator screen.
- Check the brake pedal operation.
- Check to see that the lights are working.
- Turn the steering wheel to the left and right to check the steering response.
- Stop the engine and wait for moving parts to stop, then check for oil leaks, loose parts, and any other noticeable malfunctions.

If any of the above items are not correct, notify your mechanic or check with your supervisor before taking the vehicle out for the day. Your supervisor may want you to check other items on a daily basis, so ask what your responsibilities are.

## Starting the Engine

1. Sit on the operator's seat and engage the parking brake.
2. Disengage the PTO and high flow hydraulics (if so equipped) and move the hand throttle lever to the Off position (if so equipped).
3. Move the shift lever to the Neutral position and press the clutch pedal.
4. Ensure that the hydraulic lift lever is in the center position.
5. Keep your foot off of the accelerator pedal.

**Note:** If the engine is **flooded**—fully press the accelerator pedal and hold it to the floor until the engine starts. Never pump the accelerator pedal.

6. Insert key into ignition switch and rotate it clockwise to start the engine. Release key when engine starts.

**Important:** To prevent overheating of the starter motor, do not engage starter longer than 15 seconds. After 15 seconds of continuous cranking, wait 60 seconds before engaging starter motor again.

## Driving the Vehicle

1. Release the parking brake.
2. Fully press the clutch pedal.
3. Move the gear shift lever to 1st gear.

4. Release the clutch pedal smoothly while pressing the accelerator pedal.
5. When the vehicle gains enough speed, remove your foot from the accelerator pedal, fully press the clutch pedal, move the gear shift lever to the next gear and release the clutch pedal while pressing the accelerator pedal. Repeat the procedure until the desired speed is attained.

**Important:** Always stop the vehicle before shifting to reverse a forward gear or to a forward gear from reverse.

**Note:** Avoid long periods of engine idling.

Use the chart below to determine the ground speed of the vehicle at 3600 RPM.

Gear	Range	Ratio	Speed (mph)	Speed (kmh)
1	L	82.83 : 1	2.9	4.7
2	L	54.52 : 1	4.5	7.2
3	L	31.56 : 1	7.7	12.5
1	H	32.31 : 1	7.6	12.2
2	H	21.27 : 1	11.5	18.5
3	H	12.31 : 1	19.8	31.9
R	L	86.94 : 1	2.8	4.5
R	H	33.91 : 1	7.1	11.6

**Note:** Leaving ignition switch in the On position for long periods of time without running the engine will discharge the battery.

**Important:** Do not attempt to push or tow vehicle to get it started. Damage to the drive train could result.

## Stopping the Vehicle

To stop the vehicle, remove your foot from the accelerator pedal, press the clutch pedal, then press the brake pedal.

## Stopping the Engine

To stop the engine, rotate the ignition key to the Off position and engage the parking brake. Remove the key from the switch to prevent accidental starting.

## New Vehicle Break-in

Your Workman is ready for work. To provide proper performance and long vehicle life, follow these guidelines for the first 100 operating hours.

- Check the fluid and engine oil levels regularly and be alert for indications of overheating in any component of the vehicle.
- After starting a cold engine, let it warm up for about 15 seconds before shifting into gear.
- Avoid racing the engine.
- To ensure optimum performance of the brake system, burnish (break-in) the brakes before use. To burnish the brakes, bring the vehicle up to full speed, apply the brakes to rapidly stop the vehicle without locking up the tires. Repeat this 10 times, waiting 1 minute between stops to avoid overheating the brakes. This is most effective if the vehicle is loaded with 1000 lb (454 kg).
- Vary vehicle speeds during operation. Avoid excessive idling. Avoid fast starts and quick stops.
- A break-in oil for the engine is not required. The original engine oil is the same type specified for regular oil changes.
- Refer to the Maintenance section for any special low hour checks.

## Checking the Interlock System

**Service Interval:** Before each use or daily

The purpose of the interlock system is to prevent the engine from cranking or starting unless the clutch pedal is pressed.

### ⚠ CAUTION

**If safety interlock switches are disconnected or damaged the machine could operate unexpectedly causing personal injury.**

- **Do not tamper with the interlock switches.**
- **Check the operation of the interlock switches daily and replace any damaged switches before operating the machine.**

**Note:** Refer to *Attachment Operator's Manual* for procedures on checking the attachment interlock system.

## Verifying the Clutch Interlock Switch

1. Sit on the operator's seat and engage the parking brake. Move the shift lever to the Neutral position.

**Note:** The engine will not crank if the hydraulic lift lever is locked in the forward position.

2. Without pressing the clutch pedal, rotate the ignition key clockwise to the Start position.

If the engine cranks or starts, there is a malfunction in the interlock system that must be repaired before operating the vehicle.

## Verifying the Hydraulic Lift Lever Interlock Switch

1. Sit on the operator's seat and engage the parking brake. Move the shift lever to the Neutral position and ensure that the hydraulic lift lever is in the center position.
2. Press clutch pedal.
3. Move the hydraulic lift lever forward and rotate the ignition key clockwise to the start position.

If engine cranks or starts, there is a malfunction in the interlock system that must be repaired before operating vehicle.

## Operating Characteristics

The vehicle is designed with safety in mind. It uses familiar automotive style controls, including the steering wheel, brake pedal, clutch pedal, accelerator pedal, and gear shifter. It is important to remember, however, that this vehicle is not a passenger car. It is a work vehicle and is designed for off road use only.

### ⚠ WARNING

**The Workman vehicle is an off-highway vehicle only, and is not designed, equipped, or manufactured for use on public streets, roads or highways.**

The vehicle has special tires, low gear ratios, a locking differential, and other features that give it extra traction. These features add to the versatility of the vehicle but, they can also get you into dangerous situations. You must keep in mind that the vehicle is not a recreation vehicle, it is not an all terrain vehicle, and, it is definitely not meant for stunt driving or horsing around. It is a work vehicle, not a play vehicle. Children should not be allowed to operate the vehicle. Anyone who operates the vehicle must be properly trained.

The driver and passenger should always use the seat belts.

If you are not experienced at driving the vehicle, practice driving it in a safe area away from other people. Be sure you are familiar with all the vehicle's controls, particularly those used for braking, steering, and transmission shifting. Learn how your vehicle handles on different surfaces. Your operating skills will improve with experience, but as in operating any vehicle, take

it easy as you begin. Be sure you know how to stop quickly in an emergency. If you need help, ask your supervisor for assistance.

Many factors contribute to accidents. You have control over several of the most important. Your actions, such as driving too fast for conditions, braking too fast, turning too sharp, and combinations of these, are frequent cause of accidents.

One of the major causes of accidents is fatigue. Be sure to take occasional breaks. It is very important that you stay alert at all times.

Never operate the vehicle, or any equipment, if you are under the influence of alcohol or other drugs. Even prescription drugs and cold medicines can cause drowsiness. Read the label on the medicine or check with your doctor or pharmacist if you are unsure about a certain medication.

One of the most important rules to follow is to go slower in unfamiliar areas. It is surprising how much damage and injury common things can cause. Tree branches, fences, wires, other vehicles, tree stumps, ditches, sand traps, streams, and other things found in most parks and golf courses can be hazardous to the operator and passenger.

Avoid driving when it is dark, especially in unfamiliar areas. If you must drive when it is dark, be sure to drive cautiously, use the head lights, and even consider adding additional lights.

## Passengers

Whenever you have a passenger riding in the vehicle make sure he or she is wearing the seat belt and holding on securely. Drive slower and turn less sharply because your passenger does not know what you are going to do next and may not be prepared for turning, stopping, accelerating, and bumps.

You and your passenger should remain seated at all times, keeping arms and legs inside the vehicle. The operator should keep both hands on steering wheel, whenever possible, and the passenger should use the hand holds provided (Figure 26 & Figure 27).

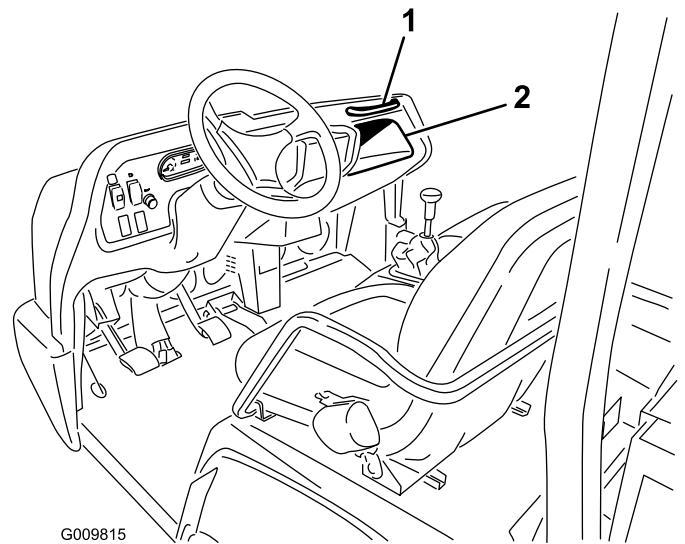

**Figure 26**

1. Passenger hand hold      2. Storage compartment

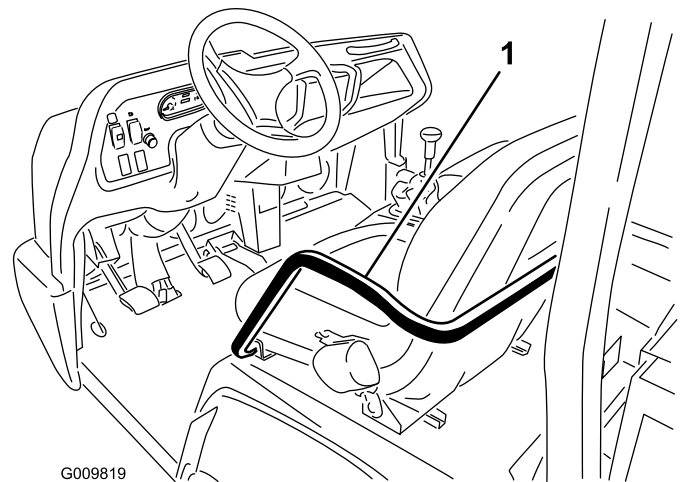

**Figure 27**

1. Hand hold & hip restraint

Never allow passengers in the dump box or on any attachments. The vehicle is meant to have one driver and only one passenger—no more.

## Speed

Speed is one of the most important variables leading to accidents. Driving too fast for the conditions can cause you to lose control and have an accident. Speed can also make a minor accident worse. Driving head-on into a tree at slow speed can cause injury and damage, but, driving into a tree at high speed can destroy the vehicle and kill you and your passenger.

Never drive too fast for the conditions. If there is any doubt about how fast to drive, slow down.

When using heavy attachments, more than 1000 lb (454 kg), such as sprayers, top dressers, or spreaders, etc., restrict your operating speed by moving the 3rd high lockout switch to the slow position.

## Turning

Turning is another important variable leading to accidents. Turning too sharply for the conditions can cause the vehicle to lose traction and skid, or even tip over.

Wet, sandy, and slippery surfaces make turning more difficult and risky. The faster you are going, the worse this situation becomes so, slow down before turning.

During a sharp turn at higher speeds, the inside rear wheel may lift off of the ground. This is not a flaw in the design, it happens with most four wheel vehicles including passenger cars. If this happens, you are turning too sharply for the speed at which you are traveling. **Slow down!**

## Braking

It is good practice to slow down before you get near an obstacle. This gives you extra time to stop or turn away. Hitting an obstacle can damage the vehicle and its contents. More important, it can injure you and your passenger. Gross vehicle weight has a major impact on your ability to stop and/or turn. Heavier loads and heavier attachments make a vehicle harder to stop or turn. The heavier the load, the longer it takes to stop

The braking characteristics also change with no bed or attachment on the vehicle. Fast stops may cause the rear wheels to lock up before the front wheels lock up, which may affect the control of the vehicle. It is a good idea to decrease vehicle speed with no bed or attachment.

Turf and pavement are much slipperier when they are wet. It can take 2 to 4 times as long to stop on wet surfaces as on dry surfaces.

If you drive through standing water deep enough to get the brakes wet, they will not work well until they are dry. After driving through water, you should test the brakes to make sure they work properly. If they do not, drive slowly in first gear while putting light pressure on the brake pedal. This will dry the brakes out.

Do not downshift for braking on icy or slippery surfaces (wet grass) or while going down a hill because engine braking may cause skidding and loss of control. Shift to a lower gear before starting down a hill.

## Tip Overs

The vehicle is equipped with a roll bar, hip restraints, seat belts, and hand hold. The ROPS system (Rollover Protection System) used on the vehicle will reduce the risk of serious or fatal injury in the unlikely event of a tip over, although the system cannot protect the operator from all possible injuries.

Replace a damaged ROPS, do not repair or revise. Any alteration of the ROPS must be approved by the manufacturer.

The best way to prevent accidents involving utility vehicles is through continuous supervision and training of operators and paying constant attention to the area in which vehicle is being operated.

The best way for operators to prevent serious injury or death to themselves or others, is to familiarize themselves with the proper operation of the utility vehicle, to stay alert and to avoid actions or conditions which could result in an accident. In the event of a tip over, the risk of serious injury or death will be reduced if the operator is using the ROPS system and seat belts and is following the instructions provided.

## Hills

### **▲ WARNING**

**Tippling or rolling the vehicle on a hill will cause serious personal injury.**

- **Do not operate the vehicle on steep slopes.**
- **If engine stalls or you lose headway on a hill, never attempt to turn vehicle around.**
- **Always back straight down a hill in reverse gear.**
- **Never back down in neutral or with the clutch depressed, using only the brakes.**
- **Never drive across a steep hill, always drive straight up or down.**
- **Avoid turning on a hill.**
- **Don't "drop the clutch" or slam on the brakes. Sudden speed change can initiate a tip over.**

Use extra care when on hills. Never go on hills that are extremely steep. Stopping while going down a hill will take longer than on level ground. Turning while going up or down a hill is more dangerous than turning on the level. Turns while going down hill, especially with the brakes on, and, turning up hill while traversing a

hill are particularly dangerous. Even at a slow speed and without a load, tip overs are more likely if you turn on a hill.

Slow down and shift into a lower gear before starting up or down a hill. If you have to turn while on a hill, do it as slowly and cautiously as possible. Never make sharp or fast turns on a hill.

If you stall or begin to lose headway while climbing a steep hill, quickly apply the brakes, shift to neutral, restart the engine and shift to reverse. At idle speed, the engine and transaxle drag will aid the brakes in controlling the vehicle on the hill and help you back down the hill more safely.

Reduce the weight of the load if it is a steep hill or if the load has high center of gravity. Remember, loads can shift, secure them.

**Note:** The vehicle has excellent hill climbing ability. The differential lock will increase this ability. Hill climbing traction can also be increased by adding weight to the rear of the vehicle in one of the following ways:

- Adding weight to inside of box, making sure it is secured.
- Mounting wheel weights to rear wheels.
- Adding liquid ballast (calcium chloride) to rear tires.
- Traction will increase with no passenger in front seat.

## Loading and Dumping

The weight and position of the cargo and passenger can change the vehicle center of gravity and vehicle handling. To avoid loss of control resulting in personal injury, follow these guidelines.

Do not carry loads which exceed the load limits described on the vehicle weight label.

### **⚠ WARNING**

**The bed will lower whenever the dump lever is pushed down, even when the engine is off. Turning off the engine will *not* prevent the box from lowering. Always place the safety support on the extended lift cylinder to hold the box up if you are not going to lower it right away.**

The vehicle has several combinations of boxes, platforms, and attachments available. These can be used in various combinations that allow for maximum capacity and versatility. The full sized box is 55 inches (140 cm) wide by 65 inches (165 cm) long and can hold up to 3000 lb (1360 kg) of evenly distributed cargo.

Loads vary in how they are distributed. Sand spreads out evenly and quite low. Other items, such as bricks, fertilizer or landscape timbers, stack higher in the box.

The height and weight of the load has a significant influence on tip overs. The higher a load is stacked, the more likely the vehicle is to tip over. You may find that 3000 lb (1360 kg) stacks too high for safe operation. Reducing the total weight is one way to reduce the risk of a tip over. Distributing the load as low as possible is another way to reduce the risk of a tip over.

If the load is positioned toward one of the sides, it will make the vehicle much more likely to tip over on that side. This is especially true when turning if the load is on the outside of the turn.

Never position heavy loads behind the rear axle. If the load is positioned so far to the rear that it is behind the rear axle, it will reduce the weight on the front wheels and this will reduce steering traction. With the load all the way to the back, the front wheels can even come off of the ground when going over bumps or up a hill. This will result in a loss of steering and may lead to the vehicle tipping over.

**As a general rule, position the weight of the load evenly from front to rear and evenly from side to side.**

If a load is not secured, or you are transporting a liquid in a large container such as a sprayer, it can shift. This shifting happens most often while turning, going up or down hills, suddenly changing speeds, or while driving over rough surfaces. Shifting loads can lead to tip overs. Always secure loads so that they do not shift. Never dump the load while the vehicle is sideways on the hill.

Heavy loads increase stopping distance and reduce your ability to turn quickly without tipping over.

The rear cargo space is intended for load carrying purposes only, not for passengers.

## Using The Differential Lock

The differential lock increases the vehicle's traction by locking the rear wheels so one wheel will not spin out. This can help when you have heavy loads to haul on wet turf or slippery areas, going up hills, and on sandy surfaces. It is important to remember however, that this extra traction is only for temporary limited use. Its use does not replace the safe operation, already discussed concerning steep hills and heavy loads.

The differential lock causes the rear wheels to spin at the same speed. When using differential lock your ability to make sharp turns is somewhat restricted and may scuff

the turf. Use the differential lock only when needed, at slower speeds and only in first or second gear.

## ⚠ WARNING

Tipping or rolling the vehicle on a hill will cause serious injury.

- The extra traction available with the differential lock can be enough to get you into dangerous situations such as climbing slopes that are too steep to turn around. Be extra careful when operating with the differential lock on, especially on steeper slopes.
- If the differential lock is on when making a sharp turn at a higher speed and the inside rear wheel lifts off the ground, there may be a loss of control which could cause vehicle to skid. Use the differential lock only at slower speeds.

## Four Wheel Drive (Four Wheel Drive Models Only)

The Automatic on Demand four wheel drive feature, on this vehicle does not require operator activation. The front wheel drive is not engaged (no power delivered to front wheels) until the rear wheels begin to lose traction. The bidirectional clutch senses the rear wheels slipping, engages the front wheel drive, and delivers power to the front wheels. The four wheel drive system continues to deliver power to the front wheels until the rear wheels have enough traction to move the vehicle without slipping. Once this occurs, the system stops delivering power to the front wheels and the handling characteristics become similar to that of a two wheel drive vehicle. The four wheel drive system functions in both forward and reverse, however, when turning the rear wheels will slip slightly more before power is delivered to the front wheels.

## ⚠ WARNING

Tipping or rolling the vehicle on a hill will cause serious injury.

The extra traction available with the four wheel drive feature can be enough to get you into dangerous situations such as climbing slopes that are too steep to turn around. Be careful when operating, especially on steeper slopes.

## Transporting Vehicle

For moving the vehicle long distances, use a trailer. Make sure the vehicle is secured to the trailer. Refer

to Figure 28 and Figure 29 for the location of the tie down points.

**Important:** Trailers weighing over 1500 lb (680 kg) are required to be equipped with trailer brakes.

**Note:** Load the vehicle on the trailer with the front of the vehicle facing forward. If that is not possible, secure the vehicle hood to the frame with a strap, or remove the hood and transport and secure it separately or the hood may blow off during transport.

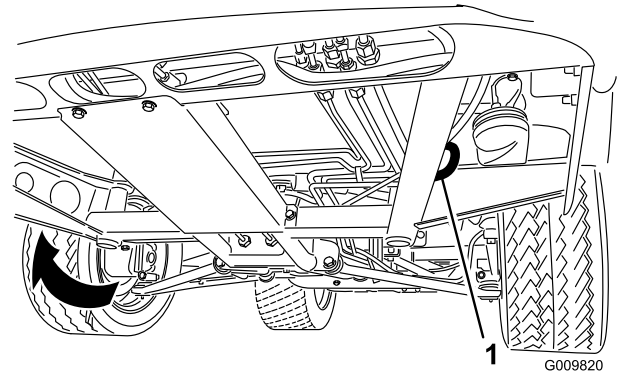

Figure 28

1. Eye hole in frame (each side)

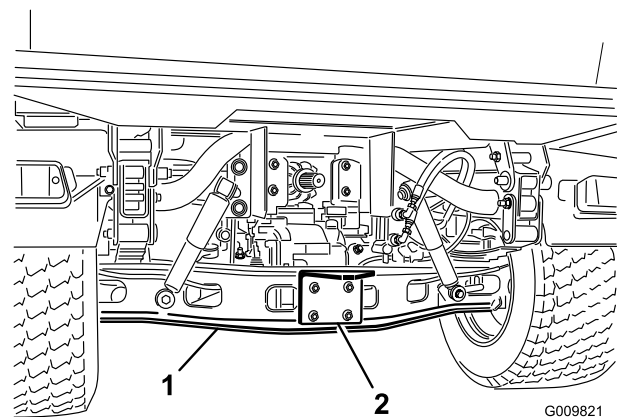

Figure 29

1. Axle
2. Hitch plate

## Towing the Vehicle

In case of an emergency, the vehicle can be towed for a short distance. However, Toro does not recommend this as a standard procedure.

## ⚠ WARNING

Towing at excessive speeds could cause vehicle to lose steering control. Never tow vehicle faster than 5 mph (8 kph).

Towing the vehicle is a two person job. Affix a tow line to holes in the front frame member. Move the shifter to

Neutral and release the parking brake. If the machine must be moved a considerable distance, transport it on a truck or trailer.

**Note:** The power steering will not function, making it difficult (increased effort) to steer.

## Towing a Trailer with the Vehicle

The Workman is capable of pulling trailers and attachments of greater weight than the vehicle itself.

Several types of tow hitches are available for the Workman, depending on your application. Contact your Authorized Toro Distributor for details.

When equipped with a tow hitch bolted onto the rear axle tube, your Workman can tow trailers or attachments with a Gross Trailer Weight (GTW) up to 3500 lb (1587 kg). Always load a trailer with 60% of the cargo weight in the front of the trailer. This places approximately 10% (600 lb (272 kg) max.) of the Gross Trailer Weight (GTW) on the tow hitch of the vehicle.

Trailer brakes are required whenever you tow a trailer over 1500 lb (680 kg) GTW is towed behind a Workman vehicle.

When hauling cargo or towing a trailer (attachment), do not overload your vehicle or trailer. Overloading can cause poor performance or damage to the brakes, axle, engine, transaxle, steering, suspension, body structure, or tires.

**Important:** To reduce potential for drive line damage, use low range.

When towing 5th wheel attachments, like a fairway aerator, always install the wheely bar (included with the 5th wheel kit) to prevent the front wheels from lifting off the ground if the towed attachments movement is suddenly impaired.

## Hydraulic Control

The hydraulic control supplies hydraulic power from the vehicle pump whenever the engine is running. The power can be used through the quick couplers at the rear of the vehicle.

**Important:** If multiple vehicles use the same attachment, cross contamination of the transmission fluid may occur. Change the transmission fluid more frequently

## Control Lever Positions

- Off Position

This is the normal position for the control valve when it is not being used. In this position the work ports of the control valve are blocked and any load will be held by the check valves in both directions.

- Raise (Quick Coupler “A” Position)

This is the position which will lift the bed, rear hitch attachment or apply pressure to quick coupler A. This also allows return oil from quick coupler B to flow back into the valve and then out to the reservoir. This is a momentary position and when the lever is released it spring returns to the center off position.

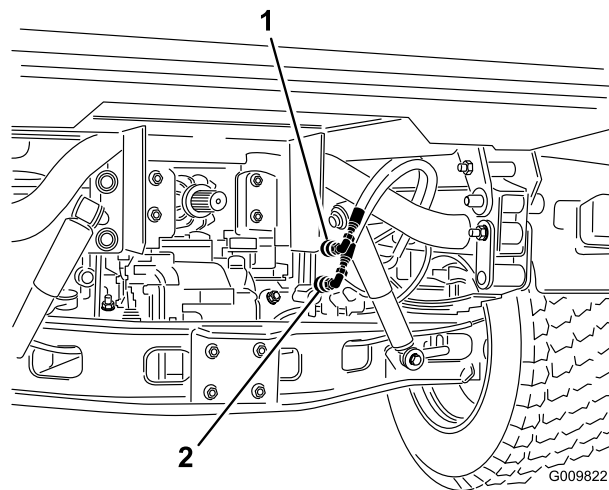

**Figure 30**

1. Quick coupler A position    2. Quick coupler B position

- Lower (Quick Coupler B Position)

This position will lower the bed, rear hitch attachment, or apply pressure to quick coupler B. This also allows return oil from quick coupler A to flow back into the valve and then out to the reservoir. This is a momentary position and when the lever is released it spring returns to the center off position. Momentarily holding and then releasing the control lever in this position will provide flow to quick coupler B which provides power down on the rear hitch. When released, it will hold the down pressure on the hitch.

**Important:** If used with a hydraulic cylinder, holding the control lever in the lower position causes the oil flow to go over a relief valve which can damage the hydraulic system.

- On Position

This position is similar to Lower (quick coupler B position). It also directs oil to quick coupler



B except that the lever is held in this position by a detent lever in the control panel. This allows oil to flow continuously to equipment that uses a hydraulic motor. This position must only be used on attachments with a hydraulic motor attached.

**Important:** If used with a hydraulic cylinder or no attachment, the On position causes the oil flow to go over a relief valve which can damage the hydraulic system. Use this position only momentarily or with a motor attached.

**Important:** Check hydraulic oil level after installation of an attachment. Check the operation of the attachment by cycling the attachment several times to purge air from system, then recheck hydraulic oil level. The attachment cylinder will slightly affect transaxle oil level. Operation of vehicle with low oil level can damage the pump, remote hydraulics, power steering, and the vehicle transaxle.

### **▲ CAUTION**

Hydraulic fluid escaping under pressure can have sufficient force to penetrate skin and do serious damage. Care must be used when connecting or disconnecting hydraulic quick couplers. Stop the engine, apply the parking brake, lower the attachment, and place the remote hydraulic valve in the float detent position to relieve hydraulic pressure before connecting or disconnecting quick couplers.

## Connecting the Quick Couplers

**Important:** Clean dirt from quick couplers before connecting. Dirty couplers can introduce contamination into the hydraulic system

1. Pull back the locking ring on the coupler.
2. Insert the hose nipple into the coupler until it snaps into position.

**Note:** When attaching remote equipment to the quick couplers, determine which side requires pressure, then attach that hose to quick coupler B which will have pressure when the control lever is pushed forward or locked in the On position.

## Disconnecting the Quick Couplers

**Note:** With both the vehicle and attachment turned off, move the lift lever back and forth to remove the system pressure and ease the disconnection of the quick couplers.

1. Pull back the locking ring on the coupler.
2. Pull the hose firmly from the coupler.

**Important:** Clean and install the dust plug and dust covers to the quick coupler ends when not in use.

## Troubleshooting the Hydraulic Control

- Difficulty in connecting or disconnecting quick couplers.
  - Pressure not relieved (Quick coupler under pressure).
- Power steering hard
  - Hydraulic oil level low
  - Hydraulic oil hot
  - Pump not operating
- Hydraulic leaks
  - Fittings loose
  - Fitting missing o-ring
- Attachment does not function
  - Quick couplers not fully engaged
  - Quick couplers are interchanged
- Squealing noise
  - Remote valve left in the On detent position causing hydraulic oil to flow over the relief valve
  - Belt loose
- The engine will not start.
  - Hydraulic lever locked in forward position

# Maintenance

Determine the left and right sides of the machine from the normal operating position.

## ⚠ CAUTION

Only qualified and authorized personnel shall be permitted to maintain, repair, adjust, or inspect the vehicle.

Avoid fire hazards and have fire protection equipment present in the work area. Do not use an open flame to check level or leakage of fuel, battery electrolyte, or coolant. Do not use open pans of fuel or flammable cleaning fluids for cleaning parts.

## ⚠ CAUTION

If you leave the key in the ignition switch, someone could accidentally start the engine and seriously injure you or other bystanders.

Remove the key from the ignition before you do any maintenance.

## Recommended Maintenance Schedule(s)

Maintenance Service Interval	Maintenance Procedure
After the first 2 hours	<ul style="list-style-type: none"> <li>• Torque the front and rear wheel nuts.</li> </ul>
After the first 8 hours	<ul style="list-style-type: none"> <li>• Check condition and tension of the alternator belt.</li> </ul>
After the first 10 hours	<ul style="list-style-type: none"> <li>• Torque the front and rear wheel nuts.</li> <li>• Check the adjustment of the shift cables.</li> <li>• Check the adjustment of the parking brake.</li> <li>• Replace the hydraulic filter.</li> <li>• Change the high flow hydraulic oil filter (TC Models only).</li> </ul>
After the first 50 hours	<ul style="list-style-type: none"> <li>• Inspect opening on filter.</li> <li>• Change engine oil and filter.</li> </ul>
Before each use or daily	<ul style="list-style-type: none"> <li>• Check engine oil level.</li> <li>• Check the level of coolant.</li> <li>• Check the transaxle/hydraulic fluid level.</li> <li>• Check the high flow hydraulic fluid level (TC models only).</li> <li>• Check the tire pressure.</li> <li>• Check the brake fluid level.</li> <li>• Check the operation of the interlock system.</li> <li>• Remove debris from the engine area and radiator. (Clean more frequently in dirty conditions.)</li> </ul>
Every 50 hours	<ul style="list-style-type: none"> <li>• Check the battery fluid level. (Every 30 days if in storage)</li> <li>• Check the battery cable connections.</li> </ul>
Every 100 hours	<ul style="list-style-type: none"> <li>• Check the level of front differential oil (four wheel drive models only).</li> <li>• Grease all bearings and bushings. (Lubricate more frequently in heavy duty applications)</li> <li>• Check the condition of the tires.</li> </ul>

Maintenance Service Interval	Maintenance Procedure
Every 200 hours	<ul style="list-style-type: none"> <li>• Torque the front and rear wheel nuts</li> <li>• Inspect opening on filter.</li> <li>• Change the air cleaner filter. (more frequently in dusty or dirty conditions)</li> <li>• Change engine oil and filter.</li> <li>• Inspect the constant velocity boot for cracks, holes, or a loose clamp (four wheel drive models only).</li> <li>• Check the adjustment of the shift cables.</li> <li>• Check the adjustment of the high-low cable.</li> <li>• Check the adjustment of the differential lock cable.</li> <li>• Check the adjustment of the parking brake.</li> <li>• Check the adjustment of the brake pedal.</li> <li>• Check condition and tension of the alternator belt.</li> <li>• Check the adjustment of the clutch pedal.</li> <li>• Inspect the service and parking brakes.</li> </ul>
Every 400 hours	<ul style="list-style-type: none"> <li>• Inspect or replace the spark plugs.</li> <li>• Replace the fuel filter.</li> <li>• Check the fuel lines and connections.</li> <li>• Check the front wheel alignment.</li> <li>• Visually inspect the brakes for worn brake shoes.</li> </ul>
Every 800 hours	<ul style="list-style-type: none"> <li>• Change the front differential oil (four wheel drive models only).</li> <li>• Change the hydraulic fluid and clean the strainer.</li> <li>• Replace the hydraulic filter.</li> <li>• Change the high flow hydraulic oil and filter (TC Models only).</li> </ul>
Every 1,000 hours	<ul style="list-style-type: none"> <li>• Change the brake fluid.</li> <li>• Drain/flush the fuel tank.</li> <li>• Flush/replace the coolant system fluid.</li> </ul>
Yearly	<ul style="list-style-type: none"> <li>• Complete all yearly maintenance procedures specified in the Engine Operator's Manual.</li> </ul>

## Service Interval Chart

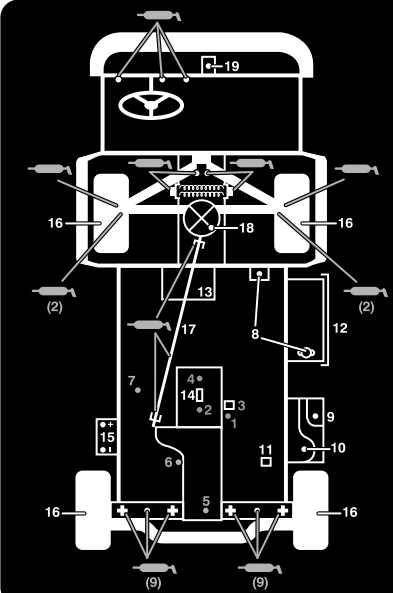

### WORKMAN QUICK REFERENCE AID CHECK/SERVICE

1. ENGINE OIL DIP STICK
2. ENGINE OIL DRAIN
3. ENGINE OIL FILTER
4. ENGINE OIL FILL
5. HYDRAULIC OIL DIP STICK
6. HYDRAULIC OIL STRAINER
7. HYDRAULIC OIL FILTER
8. COOLANT FILL
9. FUEL
10. FUEL PUMP/FILTER (EFI ONLY)
11. FUEL FILTER/WATER SEPARATOR (AC GAS & DIESEL)
12. RADIATOR SCREEN
13. AIR FILTER (LCG & DIESEL)
14. AIR FILTER (AC GAS ONLY)
15. BATTERY
16. TIRE PRESSURE - 32 PSI MAX FRONT, 18 PSI MAX REAR
17. 4WD SHAFT (4WD ONLY)
18. FRONT DIFFERENTIAL FILL (4WD ONLY)
19. BRAKE FLUID

← GREASE POINTS (100 HRS)

### FLUID SPECIFICATIONS/CHANGE INTERVALS

SEE OPERATOR'S MANUAL FOR INITIAL CHANGES	FLUID TYPE	CAPACITY		CHANGE INTERVALS	
		L	QT	FLUID	FILTER
ENGINE OIL LCG ONLY	SEE MANUAL	3.3	3.5	200 HRS.	200 HRS.
ENGINE OIL LCD ONLY	SEE MANUAL	3.3	3.5	150 HRS.	150 HRS.
ENGINE OIL AC ONLY	SEE MANUAL	1.9	2	100 HRS.	100 HRS.
TRANS/HYDRAULIC OIL	DEXRON III ATF	7.1	7.5	800 HRS.	800 HRS.
AIR CLEANER	CLEAN EVERY 50 HRS.			---	200 HRS.
FUEL	SEE MANUAL	24.6	6.5 GAL	---	400 HRS.
FUEL PUMP	---	---	---	---	400 HRS.
COOLANT 50/50 ETHYLENE GLYCOL WATER	---	3.5	3.7	1200 HRS.	---
TRANS AXLE STRAINER	---	---	---	CLEAN 800 HRS.	
DIFFERENTIAL OIL	MOBILE 424	0.25	0.26	800 HRS.	---

FOR HEAVY DUTY OPERATION, MAINTENANCE SHOULD BE PERFORMED TWICE AS FREQUENTLY.



115-7814

Figure 31

# Heavy Duty Operation

**Important:** If the vehicle is subjected to any of the conditions listed below, maintenance should be performed twice as frequently:

- Desert operation
- Cold climate operation below 32 degrees F (0 degrees C)
- Trailer towing
- Frequent operation on dusty roads
- Construction work
- After extended operation in mud, sand, water, or similar dirty conditions, have your brakes inspected and cleaned as soon as possible. This will prevent any abrasive material from causing excessive wear.

## Premaintenance Procedures

Many of the subjects covered in this maintenance section require raising and lowering the bed. The following precautions must be taken or serious injury or death could result.

### **⚠ WARNING**

Before servicing or making adjustments to the machine, stop engine, set parking brake, and remove key from the ignition switch. Remove any load material from the bed or other attachment before working under a raised bed. Never work under a raised bed without positioning the safety support on a fully extended cylinder rod.

## Using the Bed Safety Support

**Important:** Always install or remove the bed support from the outside of the bed.

1. Raise the bed until the lift cylinders are fully extended.
2. Remove the bed support from the storage brackets on back of the ROPS panel (Figure 32).

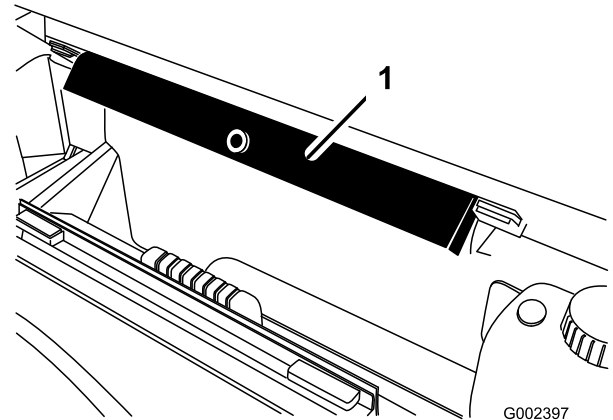

**Figure 32**

1. Bed support
3. Push the bed support onto the cylinder rod, making sure the support end tabs rest on the end of cylinder barrel and on the cylinder rod end (Figure 33).

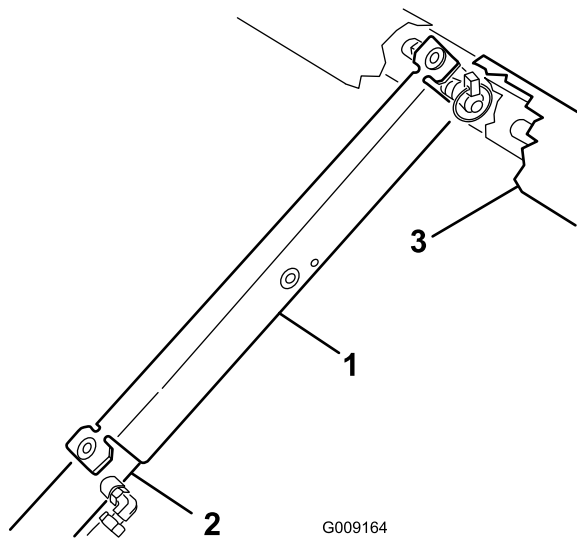

**Figure 33**

- 1. Bed support
- 2. Cylinder barrel
- 3. Bed

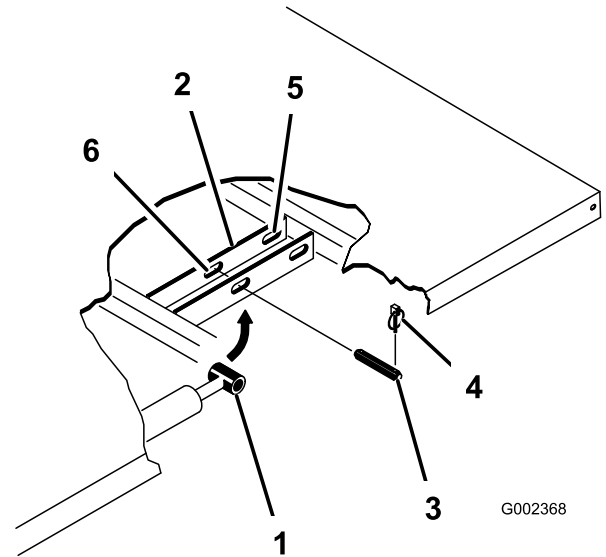

**Figure 34**

- 1. Bed mounting plate
- 2. Cylinder rod end
- 3. Clevis pin
- 4. Lynch pin
- 5. Rear slots (Full bed)
- 6. Front slots (2/3 bed)

4. When finished, remove the bed support from the cylinder and insert it into the brackets on the back of the ROPS panel.

**⚠ CAUTION**

**Do not try to lower bed with bed safety support on cylinder.**

## Removing the Full Bed

1. Start the engine. Engage the hydraulic lift lever and lower the bed until the cylinders are loose in the slots. Release the lift lever and turn off the engine.
2. Remove the lynch pins from the outer ends of the cylinder rod clevis pins (Figure 34).

3. Remove the clevis pins securing the cylinder rod ends to the bed mounting plates by pushing the pins towards the inside (Figure 34).
4. Remove the lynch pins and clevis pins securing the pivot brackets to the frame channels (Figure 34).
5. Lift the bed off of the vehicle.

**⚠ CAUTION**

**The full bed weighs approximately 325 lb (147.5 kg), so do not try to install or remove it by yourself. Use an overhead hoist or get the help of two or three other people.**

6. Store the cylinders in the storage clips. Engage the hydraulic lift lock lever on the vehicle to prevent accidental extension of the lift cylinders.

## Installing the Full Bed

**Note:** If the bed sides will be installed on the flat bed, it is easier to install them before installing the bed on the vehicle.

**Note:** Ensure that the rear pivot plates are bolted to the bed frame/channel so that lower end angles to the rear (Figure 35).

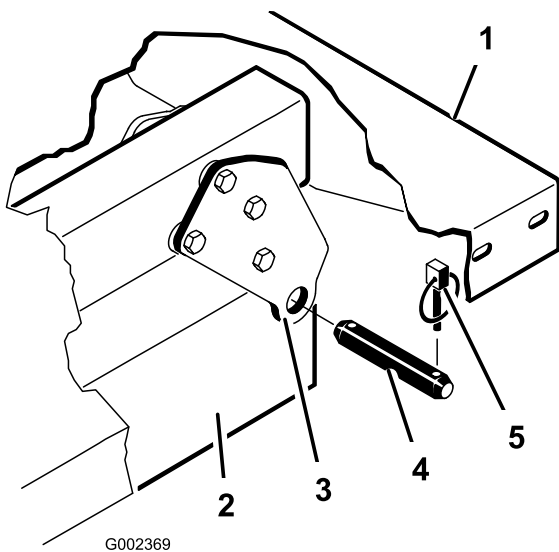

**Figure 35**

- |                            |               |
|----------------------------|---------------|
| 1. Left rear corner of bed | 4. Clevis pin |
| 2. Vehicle frame channel   | 5. Lynch pin  |
| 3. Pivot plate             |               |

### ⚠ CAUTION

The full bed weighs approximately 325 lb (147.5 kg), so do not try to install or remove it by yourself. Use an overhead hoist or get the help of two or three other people.

**Note:** Ensure that the spacer brackets and wear blocks (Figure 36) are installed with the carriage bolt heads positioned inside the machine.

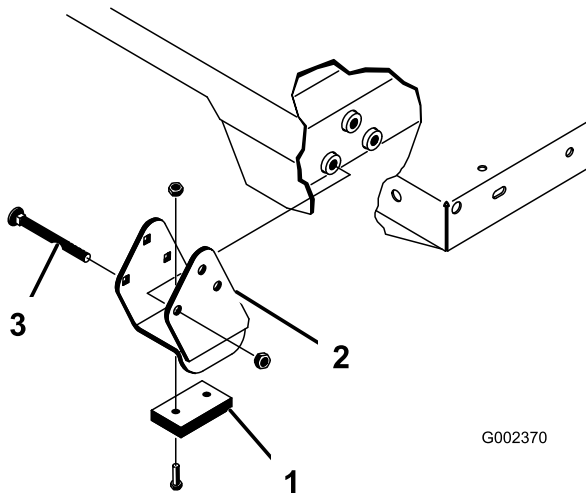

**Figure 36**

- |                   |                  |
|-------------------|------------------|
| 1. Spacer bracket | 3. Carriage bolt |
| 2. Wear block     |                  |

rear frame channel and install 2 clevis pins and lynch pins (Figure 36).

- With the bed lowered, secure each cylinder rod end, to the appropriate slots in the bed mounting plates with a clevis pin and lynch pin. Insert the clevis pin from outside of the bed with the lynch pin toward the outside (Figure 36). The rear slots are for a full bed installation and front slots are for a 2/3 bed installation.

**Note:** The engine may need to be started to extend or retract the cylinders for alignment with the holes. **Keep fingers out!**

**Note:** The unused slot can be plugged with a bolt and nut to prevent assembly errors.

- Start the engine and engage the hydraulic lift lever to raise the bed. Release the lift lever and turn off the engine. Install the bed safety support to prevent accidental lowering of the bed. Refer to Using the Bed Safety Support.
- Install the lynch pins to the inside ends of the clevis pins.

**Note:** If the automatic tail gate release has been installed on the bed, ensure that the front dump link rod has been placed on the inside of the left side clevis pin before the lynch pin is installed.

## Jacking the Vehicle

### ⚠ DANGER

A vehicle on a jack may be unstable and slip off of the jack, injuring anyone beneath it.

- Do not start the vehicle while the vehicle is on a jack.
- Always remove the key from the switch before getting off of the vehicle.
- Block the tires when the vehicle is on a jack.
- Do not start the engine while the vehicle is on a jack, because the engine vibration or wheel movement could cause the vehicle to slip off of the jack.
- Do not work under the vehicle without jack stands supporting it. The vehicle could slip off a jack, injuring anyone beneath it.
- When jacking up the front of the vehicle, always place a 2 x 4 block (or similar material) between the jack and the vehicle frame.
- The jacking point at the front of the vehicle is under the front center frame support (Figure 37) and at the rear it is under the axle (Figure 38).

- Ensure that the lift cylinders are fully retracted.
- Carefully set the bed onto the vehicle frame aligning the rear bed pivot plate holes with the holes in the

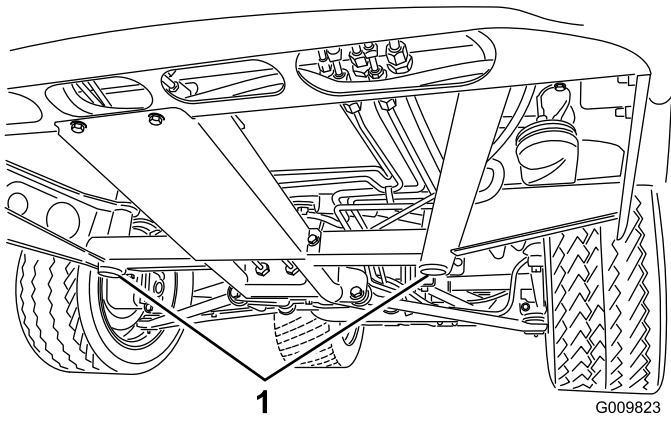

**Figure 37**

1. Front jacking points

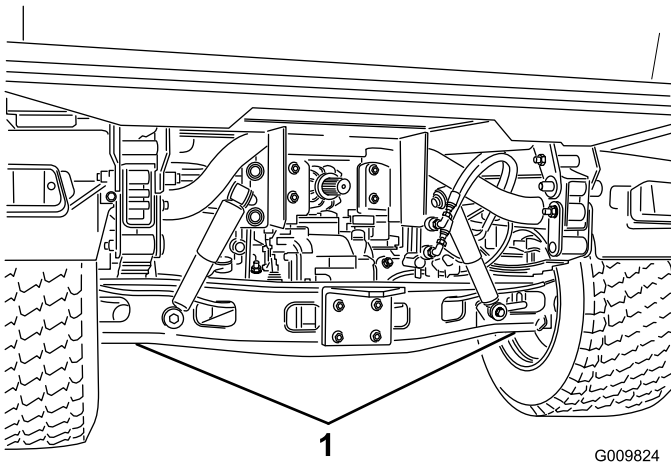
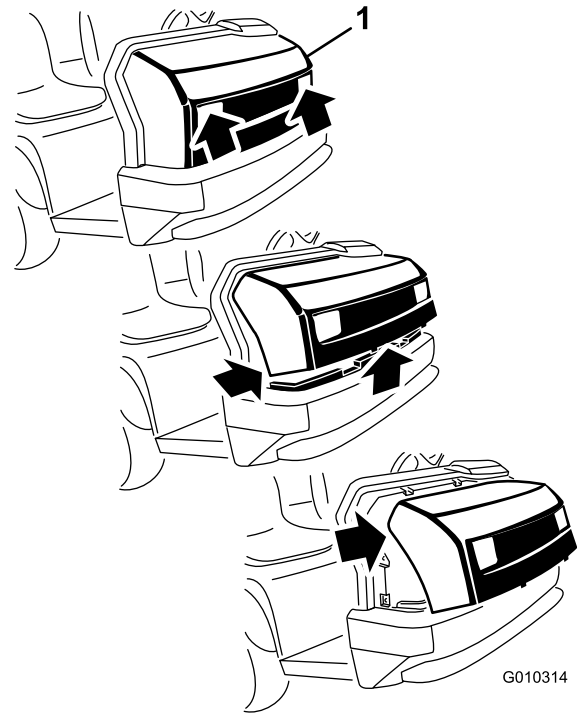

**Figure 38**

1. Rear jacking points

## Removing the Hood

1. While grasping the hood in the headlight openings, lift up on the hood to release the lower mounting tabs from the frame slots (Figure 39).



**Figure 39**

1. Hood
2. Pivot the bottom of the hood upward until the top mounting tabs can be pulled from the frame slots (Figure 39).
3. Pivot the top of hood forward and unplug the wire connectors from the head lights (Figure 39).
4. Remove the hood.

To install the hood, complete the following:

1. Connect the lights.
2. Insert the top mounting tabs into the frame slots.
3. Insert the lower mounting tabs into the frame slots.
4. Ensure that the hood is fully engaged in the top, sides and bottom grooves.

# Lubrication

## Greasing Bearings and Bushings

**Service Interval:** Every 100 hours (Lubricate more frequently in heavy duty applications)

The vehicle has grease fittings that must be lubricated regularly with No. 2 General Purpose Lithium Base Grease.

The grease fitting locations and quantities are as follows:

- Ball joints (4), tie rods (2) pivot mounts (2) and steering cylinder (2) (Figure 40)
- Spring tower (2) (Figure 41)
- Clutch (1), accelerator (1), brake (1) (Figure 42)
- Accelerator arm (1) (Figure 43)
- U-joint (18), and 4 wheel drive shaft (3) (Figure 44)

**Important:** When greasing the drive shaft universal shaft bearing crosses, pump grease until it comes out of all 4 cups at each cross.

1. Wipe each grease fitting clean so foreign matter cannot be forced into the bearing or bushing.
2. Pump grease into each bearing or bushing.
3. Wipe off excess grease.

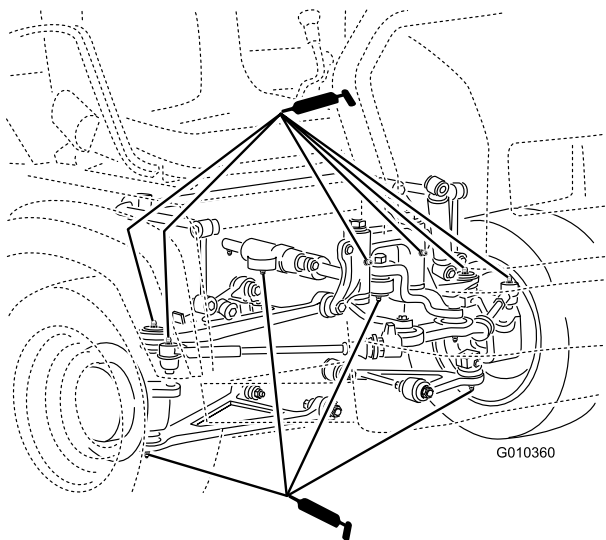

Figure 40

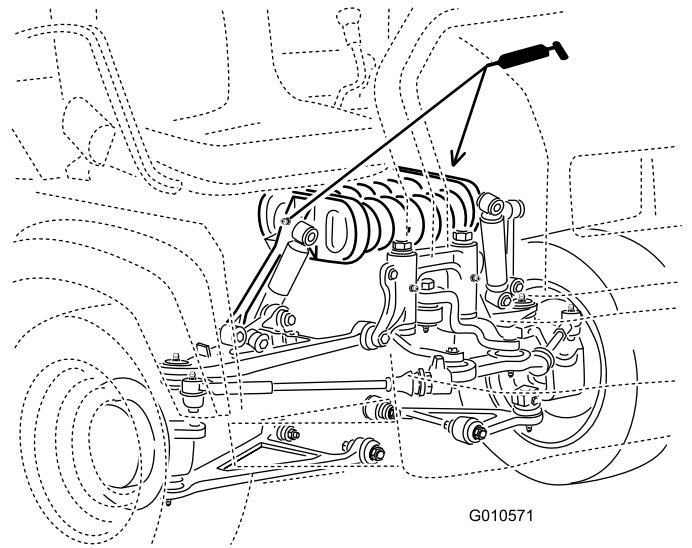

Figure 41

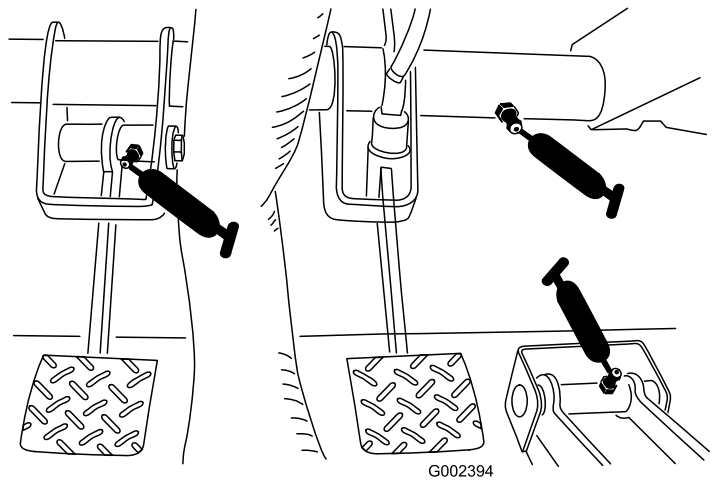

Figure 42

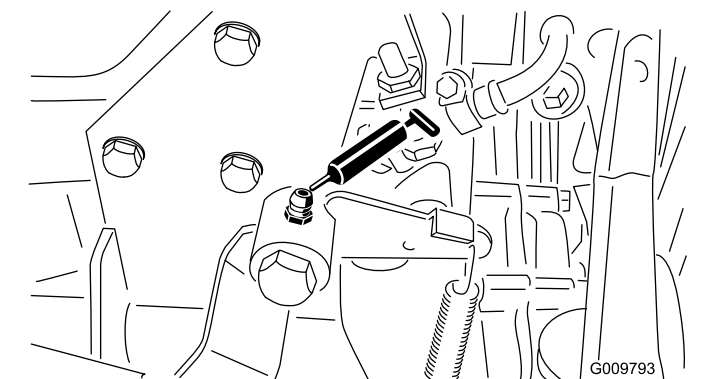
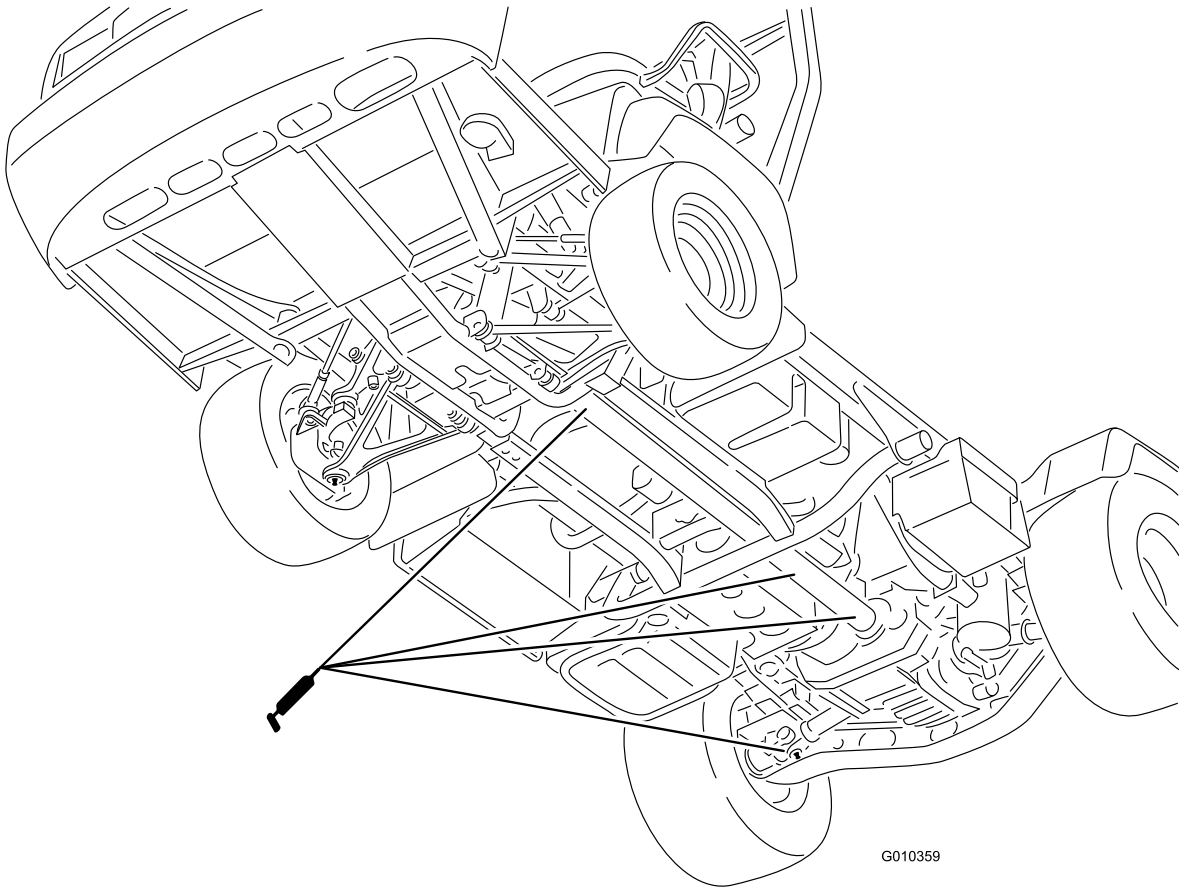

Figure 43





G010359

**Figure 44**

# Engine Maintenance

## Inspecting the Carbon Canister Air Filter

**Service Interval:** After the first 50 hours

Every 200 hours

1. Locate the air filter on the bottom of the carbon canister (Figure 45).

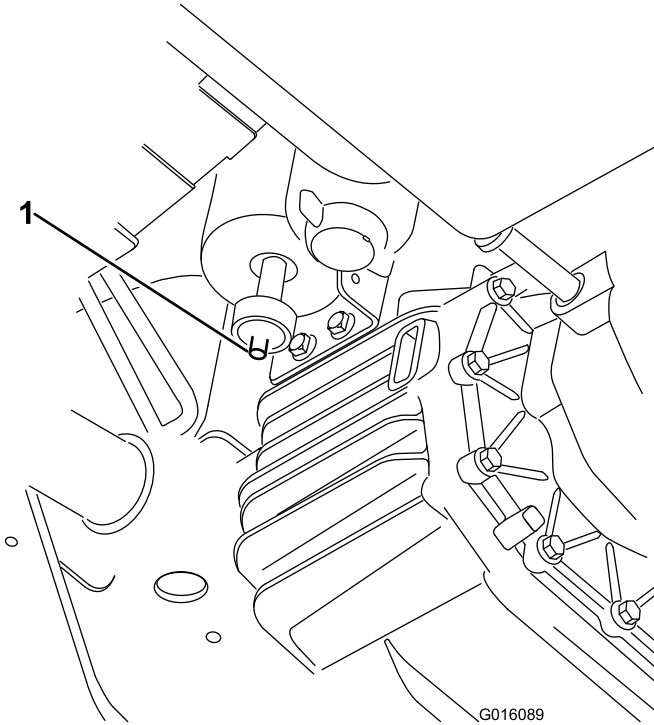

**Figure 45**

1. Filter opening

2. Ensure that the opening on the bottom of the filter is clear and open.

## Servicing the Air Cleaner

**Service Interval:** Every 200 hours—Change the air cleaner filter. (more frequently in dusty or dirty conditions)

Inspect the air cleaner and hoses periodically to maintain maximum engine protection and to ensure maximum service life. Check the air cleaner body for damage which could possibly cause an air leak. Replace a damaged air cleaner body.

Inspect and change the air cleaner filter as described in the following procedure:

1. Pull the latch outward and rotate the air cleaner cover counterclockwise.

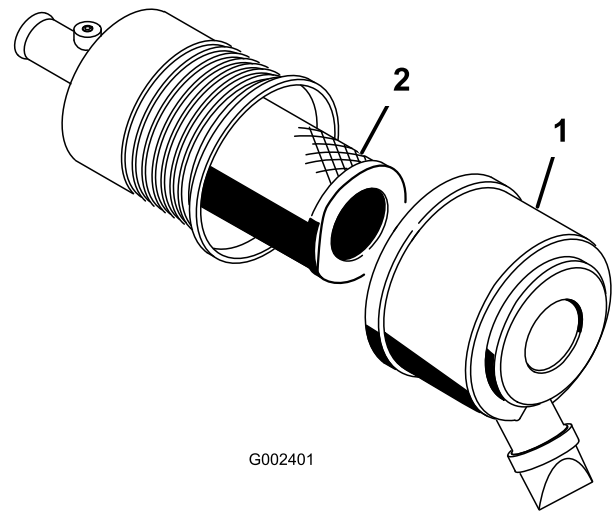

G002401

**Figure 46**

1. Air cleaner cover
2. Filter

2. Before removing the filter, use low pressure air (40 psi, clean and dry) to help remove large accumulations of debris packed between the outside of the primary filter and the canister.

**Important:** Avoid using high pressure air which could force dirt through the filter into the intake tract. This cleaning process prevents debris from migrating into the intake when the primary filter is removed.

3. Remove and replace the primary filter.

**Note:** Cleaning of the used element is not recommended due to the possibility of damage to the filter media.

4. Inspect the new filter for shipping damage, checking the sealing end of the filter and the body.

**Important:** Do not use a damaged element.

5. Insert the new filter by applying pressure to the outer rim of the element to seat it in the canister.
6. Clean the dirt ejection port located in the removable cover. Remove the rubber outlet valve from the cover, clean the cavity, and replace the outlet valve.
7. Install the cover orienting the rubber outlet valve in a downward position—between approximately 5:00 to 7:00 when viewed from the end.
8. Secure the cover latches. Reset the indicator if it is showing red (if so equipped).

## Changing the Engine Oil And Filter

**Service Interval:** After the first 50 hours

Every 200 hours

1. Raise the bed (if so equipped) and place the safety support on the extended lift cylinder to hold up the bed.
2. Remove the drain plug and let oil flow into a drain pan (Figure 47). When the oil stops, install the drain plug.

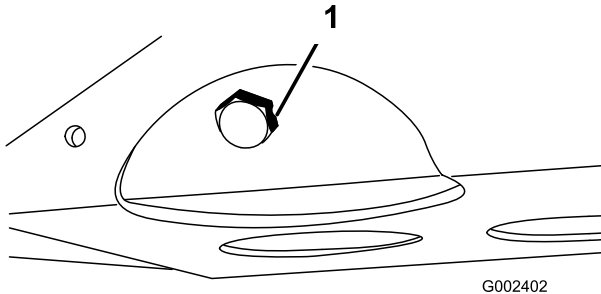

**Figure 47**

1. Engine oil drain plug

3. Remove the oil filter (Figure 48).

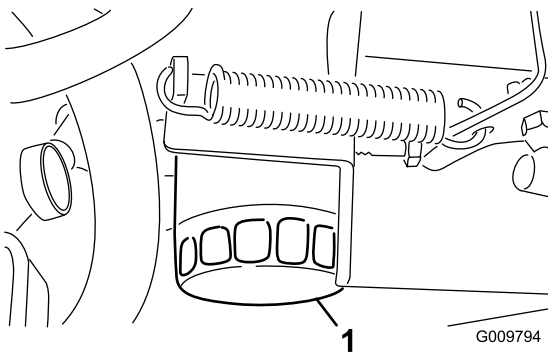

**Figure 48**

1. Engine oil filter

4. Apply a light coat of clean oil to the new filter seal before screwing it on.
5. Screw the filter on until the gasket contacts the mounting plate, then tighten the filter 1/2 to 2/3 of a turn. **Do not overtighten.**
6. Add oil to the crankcase; refer to Checking the Engine Oil Level.

## Replacing the Spark Plugs

**Service Interval:** Every 400 hours

The spark plugs usually last a long time; however, the plugs should be removed and checked whenever the engine malfunctions or every 400 hours. Replace the spark plugs to ensure proper engine performance and reduce exhaust emission level.

The correct spark plug to use is a Champion RC 14YC or NGK BPR 4ES.

The recommended air gap is 0.032 inch (0.81 mm).

1. Clean the area around the spark plugs so foreign matter cannot fall into the cylinder when you remove the spark plug.
2. Pull wires off of the spark plugs and remove the plugs from the cylinder head.
3. Check the condition of the side electrode, center electrode, and center electrode insulator to ensure that there is no damage.

**Important:** A cracked, fouled, dirty, or otherwise malfunctioning spark plug must be replaced. Do not sand blast, scrape, or clean electrodes by using a wire brush because grit may eventually release from the plug and fall into the cylinder. The result is usually a damaged engine.

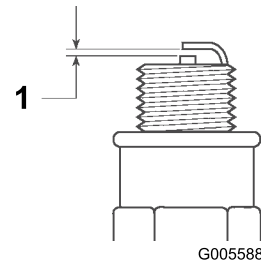

**Figure 49**

1. Air gap at 0.032 inch (0.81 mm)

4. Set the air gap on each plug between the center and side electrodes at 0.032 inch (0.81 mm).
5. Install the correctly gapped spark plugs and tighten them to 18 to 22 ft-lb (24.5 to 29 N-m). If you cannot use a torque wrench, tighten the plugs firmly.
6. Install the spark plug wires.

# Fuel System Maintenance

## Replacing the Fuel Filter

**Service Interval:** Every 400 hours

1. Raise the bed (if so equipped) and place the safety support on the extended lift cylinder to hold up the bed.
2. Unplug the wire harness connectors from the fuel pump (Figure 50).
3. Loosen the hose clamp and disconnect the fuel line from the fuel pump cap (Figure 50).

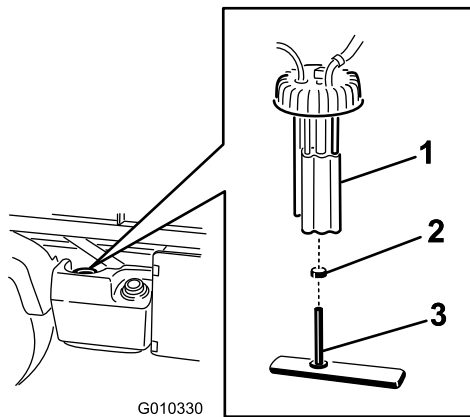

**Figure 50**

1. Fuel pump
2. Hose clamp
3. Fuel line/fuel filter

4. Un-thread the fuel pump cap from the top of the fuel tank (Figure 50).
5. Remove the fuel pump assembly and fuel filter from the tank (Figure 50).
6. Remove the clamp securing the fuel filter hose to the fuel pump fitting. Remove the hose from the fitting (Figure 50).
7. Insert the new hose clamp onto the new fuel filter hose.
8. Insert the hose onto the fuel pump and secure the clamp.
9. Insert the assembly into the fuel tank and tighten the cap to 175 to 200 in-lb (20 to 22 N-m).
10. Connect the wires and secure the hose with the hose clamp.

## Fuel Lines and Connections

**Service Interval:** Every 400 hours/Yearly (whichever comes first)

Every 1,000 hours/Every 2 years (whichever comes first)

Inspect the fuel lines and connections for deterioration, damage, or loose connections.

# Electrical System Maintenance

## Fuses

The fuses for the machine's electrical system are located under the center of the dash panel (Figure 51 and Figure 52).

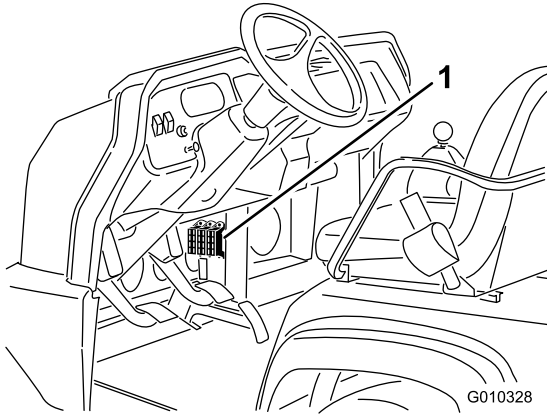

Figure 51

1. Fuses

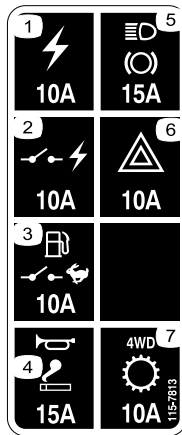

Figure 52

## Jump Starting the Vehicle

### ⚠ WARNING

Jump starting can be dangerous. To avoid personal injury or damage to electrical components in vehicle, observe the following warnings:

- Never jump start with a voltage source greater than 15 volts D.C. This will damage the electrical system.
  - Never attempt to jump start a discharged battery that is frozen. It could rupture or explode during jump starting.
  - Observe all battery warnings while jump starting your vehicle.
  - Be sure your vehicle is not touching the jump start vehicle.
  - Connecting cables to the wrong post could result in personal injury and/or damage to the electrical system.
1. Squeeze the battery cover to release the tabs from battery base. Remove the battery cover from the battery base (Figure 53).

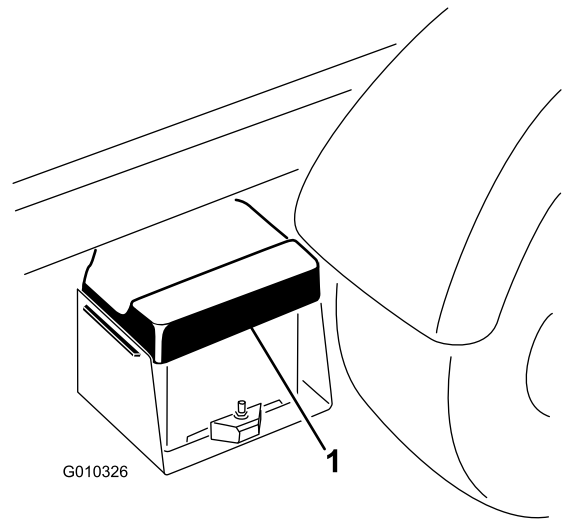
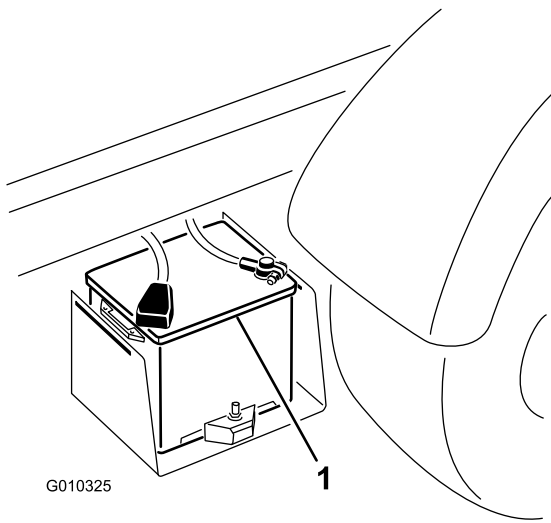

Figure 53

1. Battery cover

2. Connect a jumper cable between the positive posts of the two batteries (Figure 54). The positive post may be identified by a + sign on top of the battery cover.
3. Connect one end of the other jumper cable to the negative terminal of the battery in the other vehicle. The negative terminal has NEG on the battery cover. Do not connect the other end of the jumper cable to the negative post of the discharged battery. Connect it to the engine or frame. Do not connect the jumper cable to the fuel system.



**Figure 54**

1. Battery

4. Start the engine in the vehicle providing the jump start. Let it run a few minutes, then start your engine.
5. Remove the negative jumper cable first from your engine, then the battery in the other vehicle.
6. Install the battery cover to the battery base.

## Servicing the Battery

**Service Interval:** Every 50 hours—Check the battery fluid level. (Every 30 days if in storage)

Every 50 hours—Check the battery cable connections.

### **⚠ DANGER**

Battery electrolyte contains sulfuric acid which is a deadly poison and causes severe burns.

- Do not drink electrolyte and avoid contact with skin, eyes or clothing. Wear safety glasses to shield your eyes and rubber gloves to protect your hands.
- Fill the battery where clean water is always available for flushing the skin.
- Keep battery electrolyte level properly maintained.
- Keep the top of the battery clean by washing it periodically with a brush dipped in ammonia or bicarbonate of soda solution. Flush the top surface with water after cleaning. Do not remove the fill cap while cleaning.
- Ensure that the battery cables are kept tight on the terminals to provide good electrical contact.
- If corrosion occurs at terminals, remove the battery cover, disconnect the cables (negative (–) cable first), and scrape the clamps and terminals separately. Reconnect the cables (positive (+) cable first) and coat the terminals with petroleum jelly.
- Maintain cell electrolyte level with distilled or demineralized water. Do not fill the cells above the bottom of the fill ring inside each cell.
- If you store the machine in a location where temperatures are extremely high, the battery will run down more rapidly than if the machine is stored in a location where temperatures are cool.

### **WARNING**

#### **CALIFORNIA Proposition 65 Warning**

Battery posts, terminals, and related accessories contain lead and lead compounds, chemicals known to the State of California to cause cancer and reproductive harm.  
Wash hands after handling.

# Drive System Maintenance

## Changing the Front Differential Oil (Four Wheel Drive Models Only)

**Service Interval:** Every 800 hours

1. Position the vehicle on a level surface, stop the engine, engage the parking brake and remove the key from the ignition switch.
2. Clean the area around the drain plug on the side of the differential (Figure 55). Place a drain pan under the drain plug.

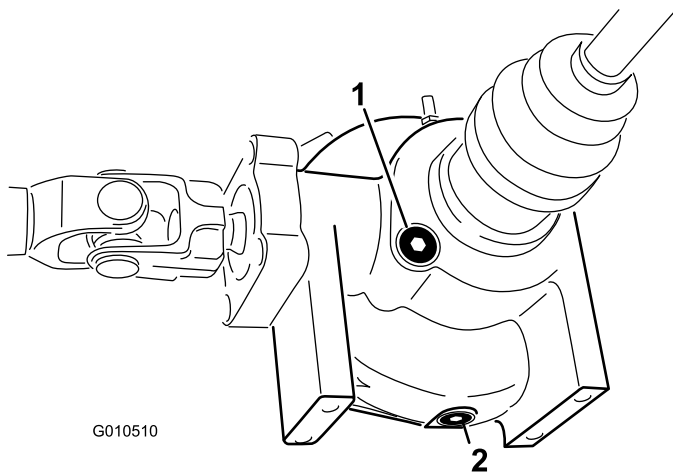

**Figure 55**

1. Fill/check plug
2. Drain plug

3. Remove the drain plug and let the oil flow into the drain pan. Install and tighten the plug when the oil stops draining.
4. Clean the area around the fill/check plug on the bottom of the differential.
5. Remove the fill/check plug and add Mobil 424 hydraulic oil until the oil is up to the hole.
6. Install the fill/check plug.

## Inspecting the Constant Velocity Boot (Four Wheel Drive Models Only)

**Service Interval:** Every 200 hours

Inspect the constant velocity boot for cracks, holes, or a loose clamp. Contact your Authorized Toro Distributor for repair if you find any damage.

## Adjusting the Shift Cables

**Service Interval:** After the first 10 hours

Every 200 hours

1. Move shift lever to the Neutral position.
2. Remove the clevis pins securing the shift cables to the transaxle shift arms (Figure 56).

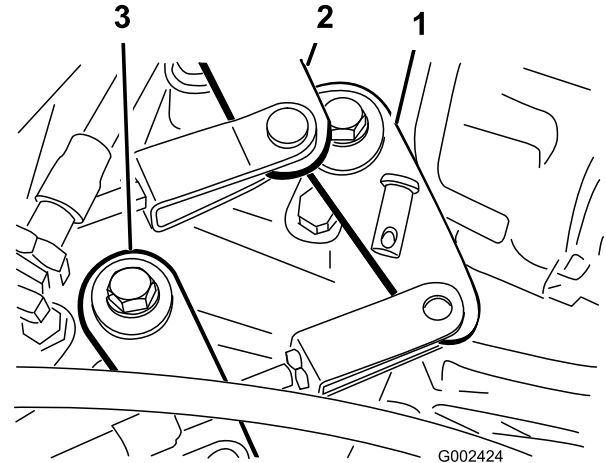

**Figure 56**

1. Shift arm (1st—Rev.)
2. Shift arm (2nd—3rd)
3. Shift arm (High—low)

3. Loosen the clevis jam nuts and adjust each clevis so cable free play is equal forward and backward relative to the hole in the transaxle shift arm (with the transaxle lever free play taken up in the same direction).
4. Install the clevis pins and tighten the jam nuts when finished.

## Adjusting the High—Low Cable

**Service Interval:** Every 200 hours

1. Remove the clevis pin securing the High—Low cable to the transaxle (Figure 57).
2. Loosen the clevis jam nut and adjust the clevis so that the clevis hole aligns with the hole in the transaxle bracket.
3. Install the clevis pin and tighten the jam nut when finished.

## Adjusting Differential Lock Cable

**Service Interval:** Every 200 hours

1. Move the differential lock lever to the Off position.

- Loosen the jam nuts securing the differential lock cable to the bracket on the transaxle (Figure 57).

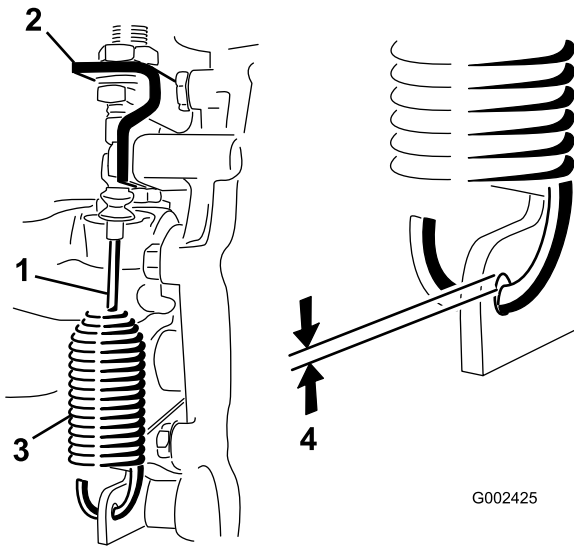

**Figure 57**

- |                            |   |
|----------------------------|---|
| 1. Differential lock cable | 3. Spring                                 |
| 2. Transaxle bracket       | 4. 0.01 to 0.06 inch (0.25 to 1.5 mm) gap |

- Adjust the jam nuts to obtain a 0.01 to 0.06 inch (0.25 to 1.5 mm) gap between the spring hook and the O.D. of the hole in the transaxle lever.
- Tighten the jam nuts when finished.

## Inspecting the Tires

**Service Interval:** Every 100 hours

Operating accidents, such as hitting curbs, can damage a tire or rim and also disrupt wheel alignment, so inspect tire condition after an accident.

Check the tire pressure frequently to ensure proper inflation. If the tires are not inflated to the correct pressure, the tires will wear prematurely.

Figure 58 is an example of tire wear caused by under inflation.

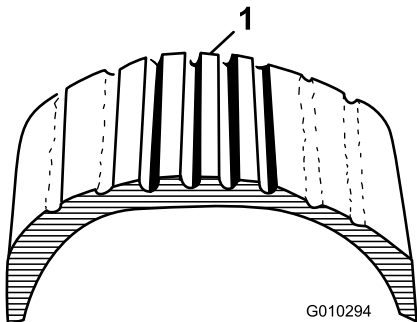

**Figure 58**

- Under inflated tire

Figure 59 is an example of tire wear caused by over inflation.

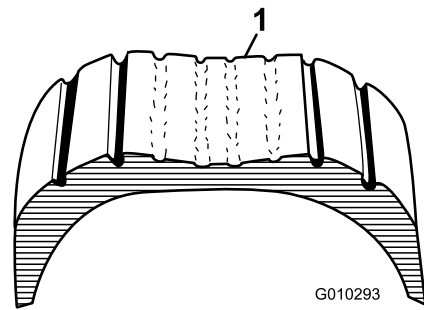

**Figure 59**

- Over inflated tire

## Checking the Front Wheel Alignment

**Service Interval:** Every 400 hours/Yearly (whichever comes first)

- Make sure the tires are facing straight ahead.
- Measure the center-to-center distance (at axle height) at the front and rear of the steering tires (Figure 60). The measurement must be within  $0 \pm 0.12$  inch ( $0 \pm 3$  mm) at the front of the tire then at the rear of the tire. Rotate the tire 90 degrees and recheck the measurement.

**Important:** Check the measurements at consistent locations on the tire. The vehicle should be on a flat surface with the tires facing straight ahead.

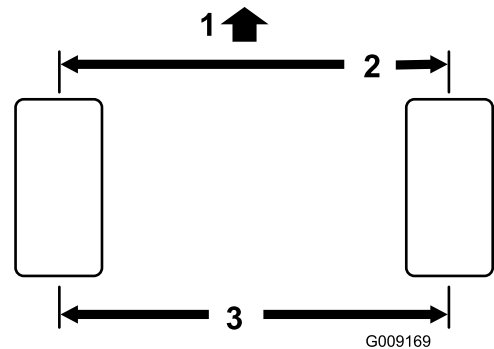
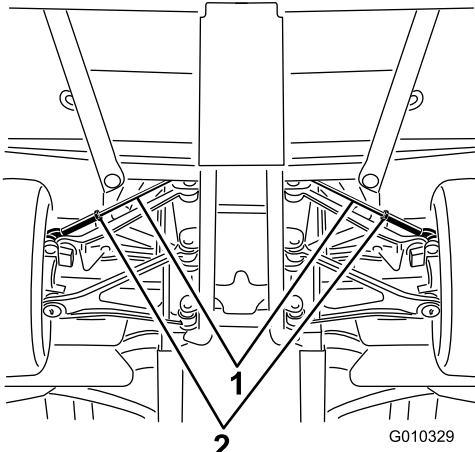

**Figure 60**

- |  |                              |
|--|------------------------------|
| 1. Front of vehicle  | 3. Center to center distance |
| 2. $0 \pm 0.12$ inch ( $0 \pm 3$ mm) front to rear of tire |                              |

- Adjust the center-to-center distance as follows:
  - Loosen the jam nut at the center of the tie rod (Figure 61).





**Figure 61**

1. Tie rods                      2. Jam nuts

- B. Rotate the tie rod to move the front of the tire inward or outward to achieve the center to center distances from front to back.
- C. Tighten the tie rod jam nut when the adjustment is correct.
- D. Check to ensure that the tires turn an equal amount to the right and to the left. If the tires do not turn equally, refer to the Workman Service Manual for the adjustment procedure

# Cooling System Maintenance

## Removing Debris from the Cooling System

**Service Interval:** Before each use or daily (Clean more frequently in dirty conditions.)

1. Turn the engine off. Clean the engine area thoroughly of all debris.
2. Unlatch and remove the radiator screen from the front of the radiator (Figure 62).

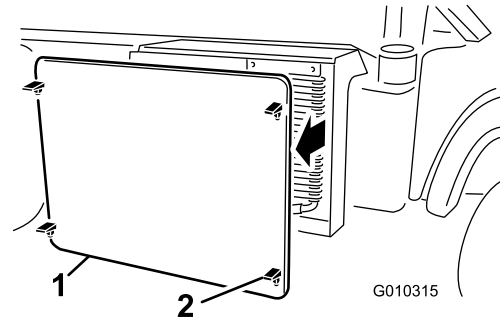

**Figure 62**

1. Radiator screen  
2. Latch

3. If so equipped, rotate the latches and pivot the oil cooler away from the radiator (Figure 63).

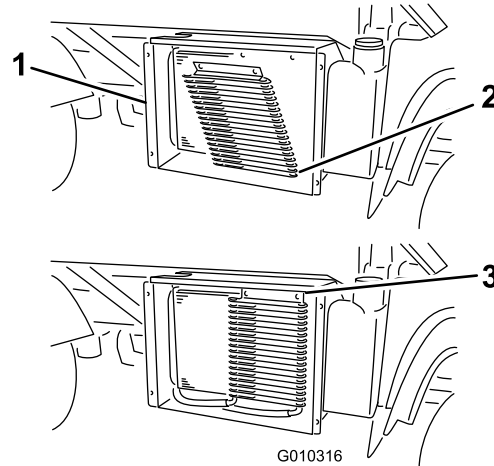

**Figure 63**

1. Radiator housing              3. Latches  
2. Oil cooler

4. Clean the radiator, oil cooler, and screen thoroughly with compressed air.

**Note:** Blow debris away from the radiator.

5. Install the cooler and screen to the radiator.

# Changing Engine Coolant

**Service Interval:** Every 1,000 hours/Every 2 years  
(whichever comes first)

1. Park the machine on a level surface.
2. Raise the bed (if so equipped) and place the safety support on the extended lift cylinder to hold up the bed.

## ⚠ CAUTION

If the engine has been running, the pressurized, hot coolant can escape and cause burns.

- Do not open the radiator cap when the engine is running.
- Allow engine to cool at least 15 minutes or until the radiator cap is cool enough to touch without burning your hand.
- Use a rag when opening the radiator cap, and open the cap slowly to allow steam to escape.

3. Remove the radiator cap.

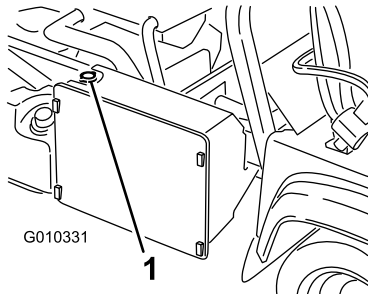

**Figure 64**

1. Radiator cap

4. Remove the reserve tank cap.

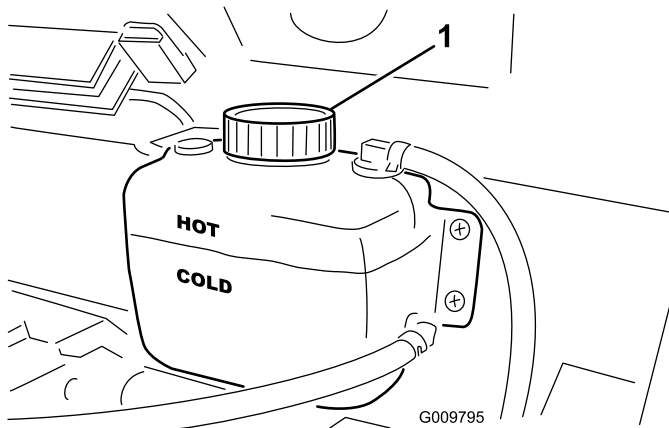

**Figure 65**

1. Reserve tank cap

5. Disconnect the lower radiator hose and allow coolant to flow into a drain pan. When coolant stops, connect the lower radiator hose.
6. Open the bleed screw on top of the water pump (Figure 66).

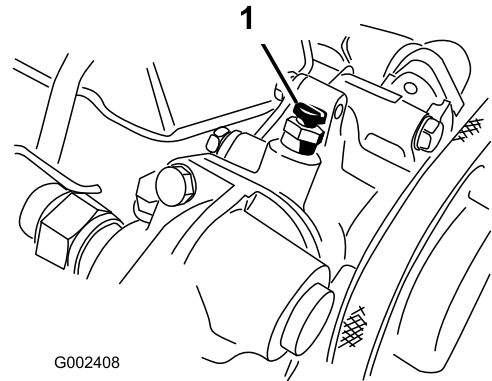

**Figure 66**

1. Bleed screw

7. Remove the coolant drain plug from the engine and allow coolant to flow into a drain pan. When coolant stops, install the drain plug.
8. Slowly fill the radiator with a 50/50 mixture of water and permanent ethylene glycol anti-freeze
9. With the bleed screw open, start the engine. Allow engine to idle until the fluid has a clean stream out of the bleed screw.
10. Close the bleed screw while the engine is running
11. Top off the radiator and install the cap.
12. Slowly fill the reserve tank until level reaches the Cold line. **Do not overfill.** Install the reserve tank cap.
13. Start the engine and operate it until warm.
14. Stop the engine. Check the coolant level and replenish it, if required.

# Brake Maintenance

## Adjusting the Parking Brake

**Service Interval:** After the first 10 hours  
Every 200 hours

1. Remove the rubber grip from the parking brake lever (Figure 67).

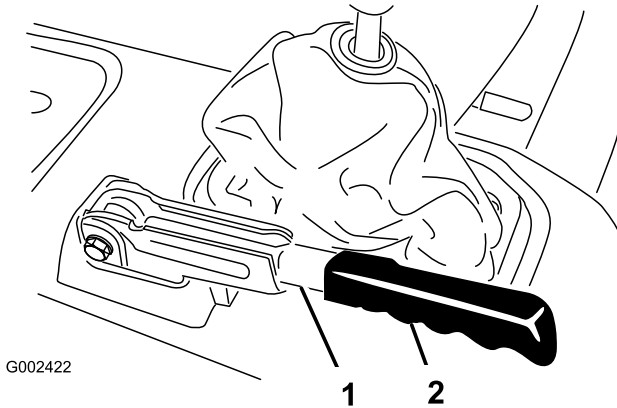

**Figure 67**

1. Parking brake lever
2. Grip

2. Loosen the set screw securing the knob to the parking brake lever (Figure 68).
3. Rotate the knob until a force of 45 to 50 lb (20 to 22 kg) is required to actuate the lever.

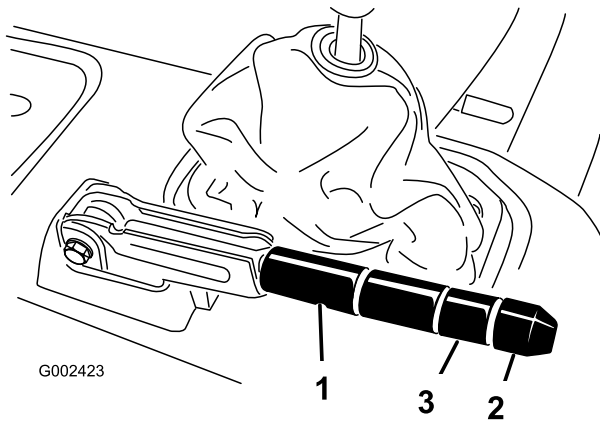

**Figure 68**

1. Parking brake lever
2. Knob
3. Set screw

4. Tighten the set screw when finished.

**Note:** If no adjustment is left at the handle, loosen the handle to the middle of the adjustment and adjust the cable at the rear, then repeat step 3.

5. Install the rubber grip onto the parking brake lever.

## Adjusting the Brake Pedal

**Service Interval:** Every 200 hours

**Note:** Remove the front hood to ease the adjustment procedure.

1. Remove the cotter pin and clevis pin securing the master cylinder yoke to the brake pedal pivot (Figure 69).

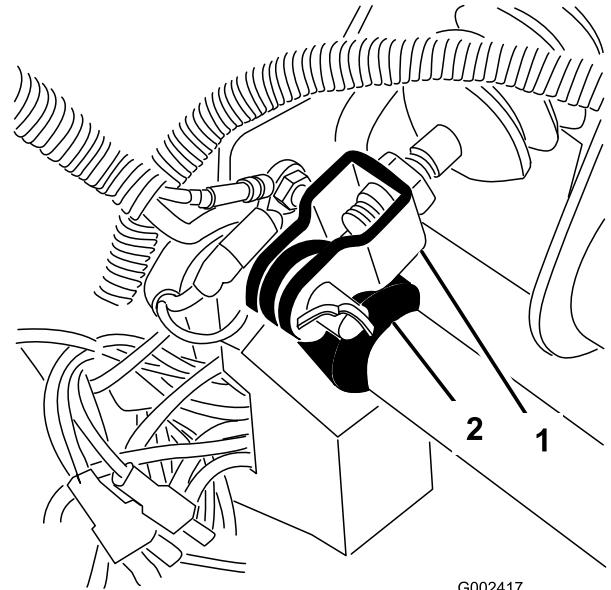

**Figure 69**

1. Master cylinder yoke
2. Brake pedal pivot

2. Lift up on the brake pedal (Figure 70) until it contacts the frame.
3. Loosen the jam nuts securing the yoke to the master cylinder shaft (Figure 70).
4. Adjust the yoke until its holes align with the hole in the brake pedal pivot. Secure the yoke to the pedal pivot with the clevis pin and cotter pin.
5. Tighten the jam nuts securing the yoke to the master cylinder shaft.

**Note:** The brake master cylinder must relieve pressure when properly adjusted.

# Belt Maintenance

## Adjusting the Alternator Belt

**Service Interval:** After the first 8 hours—Check condition and tension of the alternator belt.

Every 200 hours—Check condition and tension of the alternator belt.

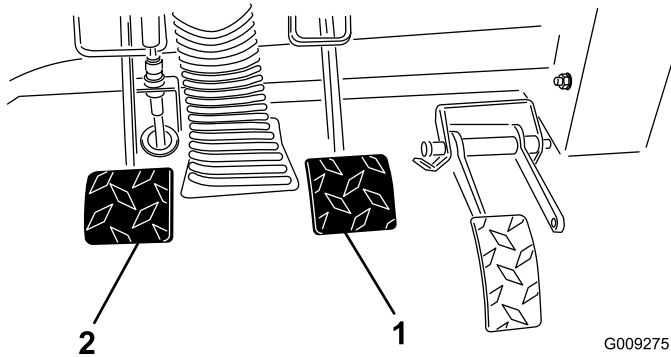

Figure 70

1. Brake pedal

2. Clutch pedal

1. Raise the bed (if so equipped) and position the safety support on the extended lift cylinder to hold up the bed.
2. Check the tension by pressing the belt at mid span between the crankshaft and alternator pulleys with 22 lb (10 kg) of force. A new belt should deflect 0.3 to 0.5 inch (8 to 12 mm). A used belt should deflect 0.4 to 0.55 inch (10 to 14 mm). If the deflection is incorrect, proceed to the next step. If correct, continue operation.
3. To adjust belt tension, complete the following:
  - Loosen the 2 alternator mounting bolts.

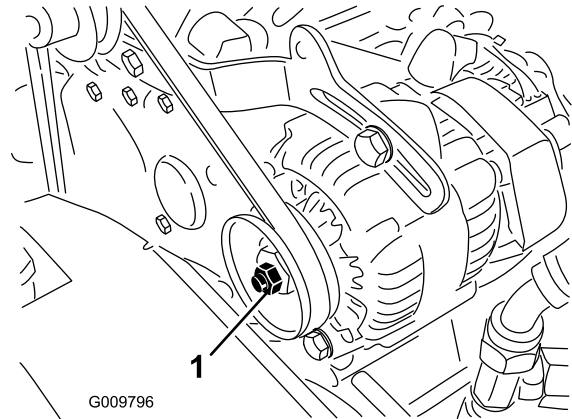

Figure 71

1. Alternator belt

2. Alternator brace

- Using a bar, rotate the alternator until the proper belt tension is attained, then tighten the mounting bolts.

# Controls System Maintenance

## Adjusting the Accelerator Pedal

1. Position the vehicle on a level surface, stop the engine, and engage the parking brake.
2. Adjust the ball joint on the accelerator cable (Figure 72) to allow 0.200 to 0.350 inch (5 to 8.9 mm) of clearance between the accelerator pedal arm and the top of the diamond tread floor plate (Figure 72), when a 20 lb (9 kg) force is applied to the center of the pedal. Tighten the locknut.

**Note:** The engine must not be running and the return spring must be attached.

### **⚠ WARNING**

The governor is preset at the factory to a maximum engine speed of 3650 rpm. If the speed is not correct, refer to the Workman Service Manual or contact your authorized Toro Dealer/Distributor for assistance.

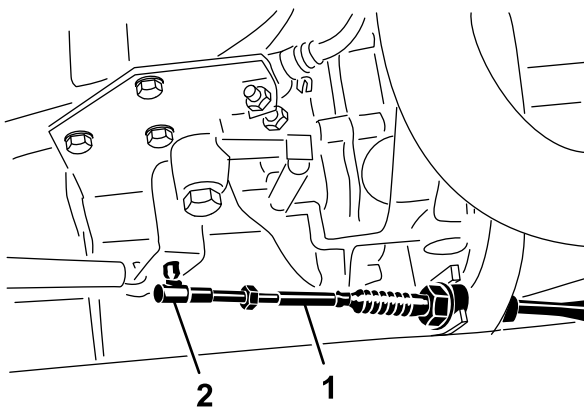

G009799

**Figure 72**

1. Accelerator cable
2. Ball joint

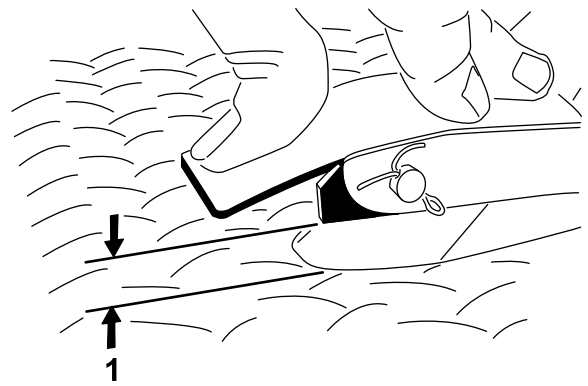

G002412

**Figure 73**

1. 0.200 to 0.350 inch (5 to 8.9 mm) clearance

## Adjusting the Clutch Pedal

**Service Interval:** Every 200 hours

**Note:** You can adjust the clutch pedal cable at the bell housing or at the clutch pedal pivot. The front hood can be removed to ease the access to pedal pivot.

1. Loosen the jam nuts securing the clutch cable to the bracket on the bell housing (Figure 74).

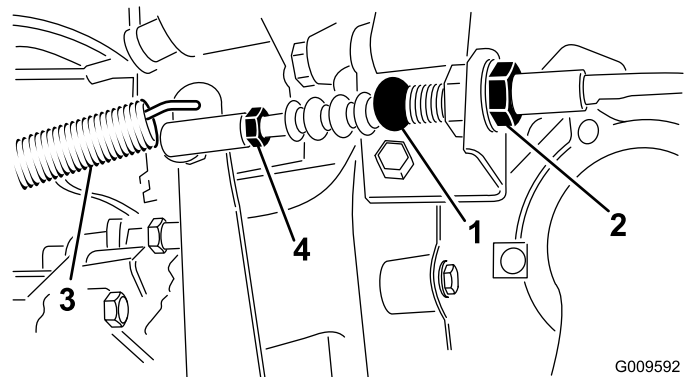

G009592

**Figure 74**

1. Clutch cable
2. Jam nuts
3. Return spring
4. Ball joint

**Note:** You may remove and rotate the ball joint, if additional adjustment is required.

2. Disconnect the return spring from the clutch lever.
3. Adjust the jam nuts or ball joint until the back, rear edge of the clutch pedal is  $3.75 \pm 0.12$  inch ( $9.5 \pm 0.3$  cm) from the top of the floor plate diamond pattern, when an 4 lb (1.8 kg) force is applied to the pedal (Figure 75).

## Converting the Speedometer

You can convert the speedometer from MPH to KPH or KPH to MPH.

1. Position the vehicle on a level surface, stop the engine, engage the parking brake, and remove the key from the ignition switch.
2. Remove the hood. Refer to Removing the Hood in the Pre-maintenance Procedures.
3. Locate the two loose wires next to the speedometer.
4. Remove the connector plug from the harness wire and connect the wires together.

The speedometer will switch to KPM or MPH.

5. Install the hood.

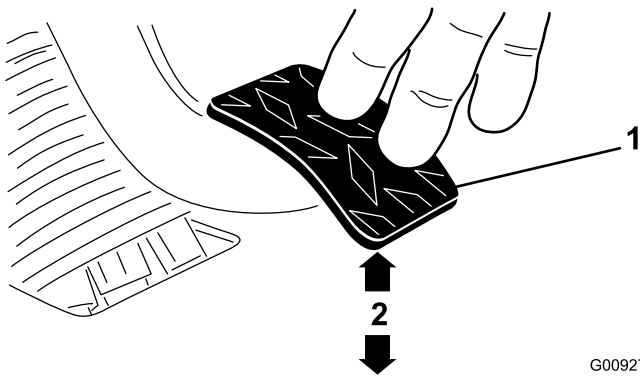

Figure 75

G009276

1. Clutch pedal
2.  $3.75 \pm 0.12$  inch ( $9.5 \pm 0.3$  cm)

**Note:** Force is applied so the clutch release bearing lightly contacts the pressure plate fingers.

4. Tighten the jam nuts after the adjustment has been attained.
5. Recheck the  $3.75 \pm 0.12$  inch ( $9.5 \pm 0.3$  cm) dimension after the jam nuts have been tightened to ensure proper adjustment. Readjust, if necessary.
6. Connect the return spring to the clutch lever.

**Important:** Ensure that the rod end is positioned squarely on the ball, not twisted, and remains parallel to the clutch pedal after the jam nut is tightened (Figure 76).

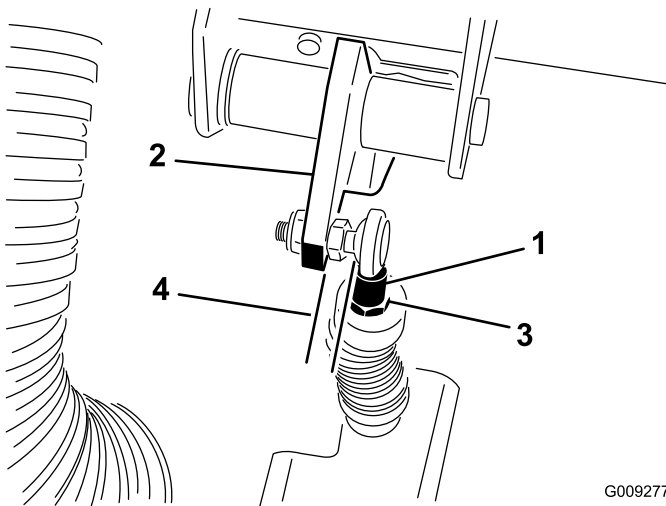

Figure 76

G009277

1. Clutch cable rod end
2. Clutch pedal
3. Rod end jam nut
4. Parallel

**Note:** The clutch free play should never be less than 0.75 inch (19 mm).

# Hydraulic System Maintenance

## Changing the Hydraulic Fluid and Cleaning the Strainer

**Service Interval:** Every 800 hours

1. Position the vehicle on a level surface, stop the engine, engage the parking brake, and remove the key from the ignition switch.
2. Remove the drain plug from the side of the reservoir and let the hydraulic fluid flow into a drain pan (Figure 77).

**Note:** Clean the hydraulic strainer. Refer to Cleaning Hydraulic Strainer.

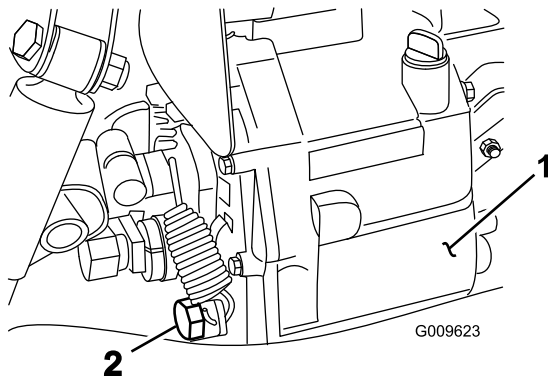

**Figure 77**

1. Hydraulic reservoir
2. Drain plug

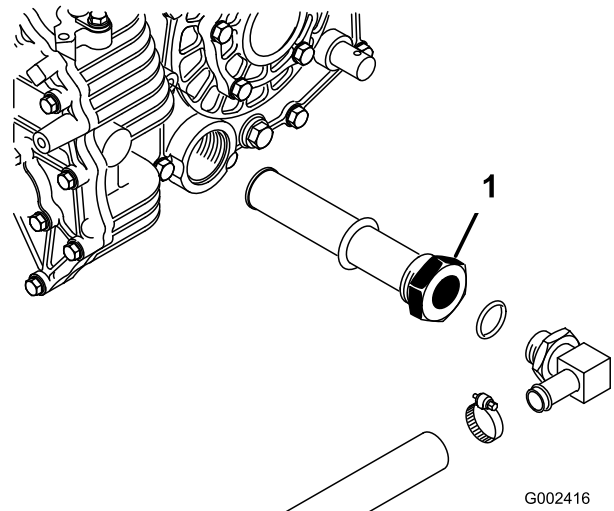

**Figure 78**

1. Hydraulic strainer

3. Note the orientation of the hydraulic hose and 90 degree fitting connected to the strainer on the side of the reservoir (Figure 78). Remove the hydraulic hose and 90 degree fitting.
4. Remove the strainer and clean it by back flushing it with a clean de-greaser. Allow it to air dry before installing.

5. Install the strainer.
6. Install the hydraulic hose and 90 degree fitting to the strainer in the same orientation.
7. Install and tighten the drain plug.
8. Fill the reservoir with approximately 7.5 qt (7 l) of Dexron III ATF. Refer to Checking the Hydraulic Fluid Level.
9. Start the engine and operate the vehicle to fill the hydraulic system. Check the hydraulic oil level and replenish it, if required.

**Important:** Use only the hydraulic fluids specified. Other fluids could cause system damage.

## Replacing the Hydraulic Filter

**Service Interval:** After the first 10 hours

Every 800 hours

**Important:** Use of any other filter may void the warranty on some components.

1. Position the vehicle on a level surface, stop the engine, engage the parking brake, and remove the key from ignition switch.
2. Clean the area around filter mounting area. Place a drain pan under the filter and remove the filter (Figure 79).

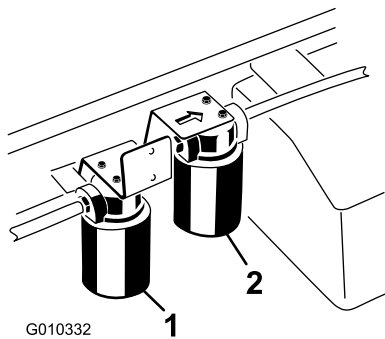

**Figure 79**

1. Hydraulic filter
2. High flow hydraulics filter

3. Lubricate the gasket on the new filter.
4. Ensure that the filter mounting area is clean. Screw the filter on until the gasket contacts the mounting plate. Then tighten the filter one-half turn.
5. Start the engine and let it run for about two minutes to purge air from the system. Stop the engine and check the hydraulic oil level and for leaks.

## Changing the High Flow Hydraulic Oil and Filter (TC Models only)

**Service Interval:** After the first 10 hours—Change the high flow hydraulic oil filter (TC Models only).

Every 800 hours—Change the high flow hydraulic oil and filter (TC Models only).

The reservoir is filled with approximately 4 US gallons (15 l) of high quality hydraulic fluid. Appropriate hydraulic oils are listed below.

**Toro Premium All Season Hydraulic Fluid** (Available in 5 gallon pails or 55 gallon drums. See parts catalog or Toro distributor for part numbers.)

**Alternate fluids:** If the Toro fluid is not available, another conventional petroleum-based fluid may be used provided it meets the following material properties and industry specifications. Consult with your lubricant distributor to identify a satisfactory product. Note: Toro will not assume responsibility for damage caused by improper substitutions, so use only products from reputable manufacturers who will stand behind their recommendation.

**High Viscosity Index/Low Pour Point Antiwear Hydraulic Fluid, ISO VG 46**

Material Properties:

- Viscosity—ASTM D445 cSt @ 40°C: 44 to 48/cSt @ 100°C: 7.9 to 8.5
- Viscosity Index, ASTM D2270—140 to 152
- Pour Point, ASTM D97— -35°F to -46°F
- FZG, Fail stage—11 or better
- Water content (new fluid)—500 ppm (maximum)

Industry Specifications:

Vickers I-286-S, Vickers M-2950-S, Denison HF-0, Vickers 35 VQ 25 (Eaton ATS373-C)

**Note:** Many hydraulic fluids are almost colorless, making it difficult to spot leaks. A red dye additive for the hydraulic system oil is available in 2/3 oz. (20 ml) bottles. One bottle is sufficient for 4–6 gal (15–22 l) of hydraulic oil. Order part no. 44-2500 from your authorized Toro distributor.

**Note:** If the oil becomes contaminated, contact your local Toro distributor because the system must be flushed. Contaminated oil may look milky or black when compared to clean oil. The service interval may need to be increased if using multiple attachments as the oil may become contaminated quicker with the mixing of different hydraulic oils.

1. Clean the area around the high flow filter mounting area (Figure 79). Place a drain pan under the filter and remove the filter.

**Note:** If the oil is not going to be drained, disconnect and plug the hydraulic line going to the filter.

2. Lubricate the new filter sealing gasket and hand turn the filter onto the filter head until the gasket contacts the filter head. Then tighten it 3/4 turn further. The filter should now be sealed.
3. Fill the hydraulic reservoir with approximately 4 US gallons (15 l) of hydraulic oil.
4. Start the machine and run it at idle for about two minutes to circulate the fluid and remove any air trapped in the system. Stop the machine and recheck the fluid level.
5. Verify the oil level.
6. Dispose of the oil properly.

## Raising the Box in an Emergency

The box can be raised in an emergency without starting the engine by cranking starter or by jumping hydraulic system.



## Raising the Box using the Starter

Crank the starter while holding the lift lever in the Raise position. Run the starter for 15 seconds then wait 60 seconds before engaging the starter again. If the engine will not crank, you must remove the load and box (attachment) to service the engine or transaxle.

## Raising the Box by Jumping the Hydraulic System

### ⚠ CAUTION

Before servicing or making adjustments to the machine, stop the engine, set the parking brake, and remove the key from the switch. Any load material must be removed from the bed or other attachment before working under a raised bed. Never work under a raised bed without positioning the safety support on the fully extended cylinder rod.

**Note:** Two hydraulic hoses, each with a male and female quick coupler, that fit the vehicle couplers are required to perform this operation.

1. Back another vehicle up to the rear of the disabled vehicle.

**Important:** The vehicles hydraulic system uses Dexron III ATF. To avoid system contamination, make sure the vehicle used to jump the hydraulic system uses an equivalent fluid.

2. On both vehicles, disconnect the two quick coupler hoses from the hoses secured to the coupler bracket (Figure 80).

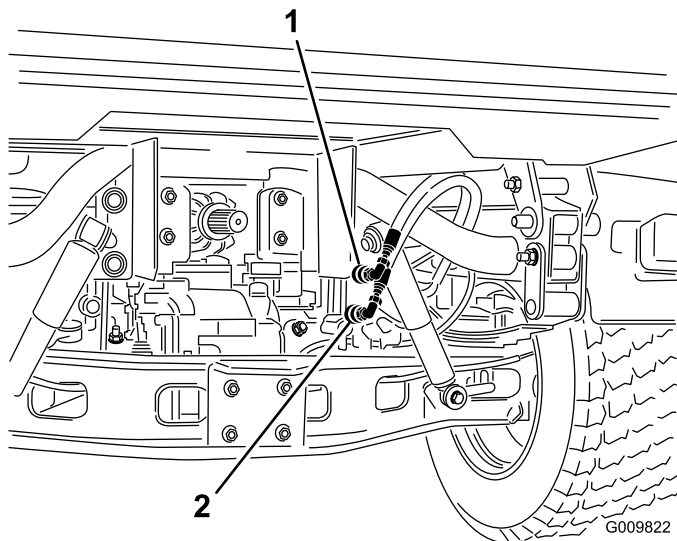

Figure 80

1. Quick coupler hose A
2. Quick coupler hose B

3. On the disabled vehicle, connect the two jumper hoses to the hoses that were disconnected (Figure 81). Cap the unused fittings.

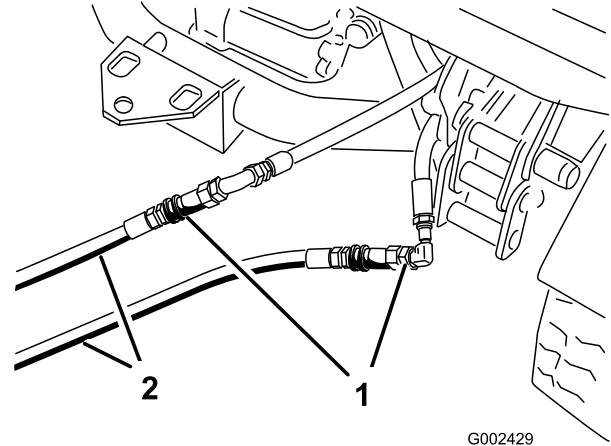

Figure 81

1. Disconnected hoses
2. Jumper hoses

4. On the other vehicle, connect the two hoses to the coupler still in the coupler bracket (connect the top hose to the top coupler and the bottom hose to the bottom coupler) (Figure 82). Cap the unused fittings.

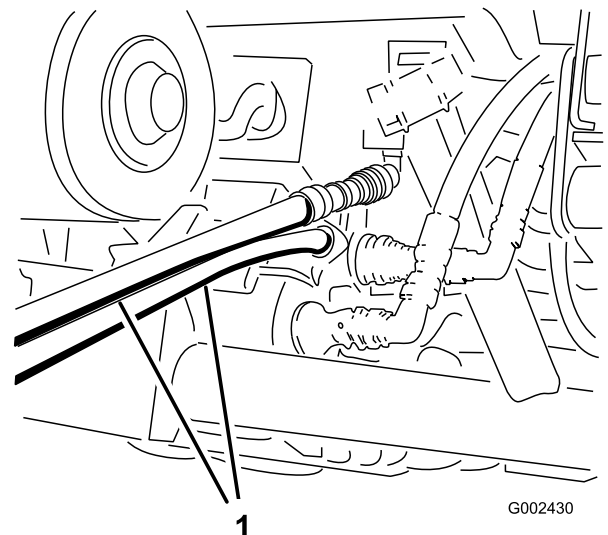

Figure 82

1. Jumper hoses

5. Keep all bystanders away from the vehicles.
6. Start the second vehicle and move the lift lever to the raise position which will raise the disabled box.
7. Move the hydraulic lift lever to the neutral position and engage the lift lever lock.
8. Install the bed safety support onto the extended lift cylinder. Refer to Using the Bed Safety Support.

**Note:** With both the vehicles turned off, move the lift lever back and forth to remove the system pressure and ease the disconnection of the quick couplers.

9. After completing the operation, remove the jumper hoses and connect the hydraulic hoses to both vehicles.

**Important:** Check the hydraulic fluid levels, in both vehicles, before resuming operation.

## Storage

1. Position the machine on a level surface, set the parking brake, stop the engine, and remove the ignition key.
2. Clean dirt and grime from the entire machine, including the outside of the engine cylinder head fins and blower housing.

**Important:** You can wash the machine with mild detergent and water. Do not use high pressure water to wash the machine. Pressure washing may damage the electrical system or wash away necessary grease at friction points. Avoid excessive use of water, especially near the control panel, lights, engine, and the battery.

3. Inspect the brakes; refer to Inspecting the Brakes.
4. Service the air cleaner; refer to Servicing the Air Cleaner.
5. Grease the machine.
6. Change the engine oil; refer to Changing the Engine Oil and Filter.
7. Check the tire pressure; refer to Checking the Tire Pressure.
8. For storage over 30 days, prepare the fuel system as follows:
  - A. Add a petroleum based stabilizer/conditioner to fuel in the tank.

Follow mixing instructions from stabilizer manufacturer. (1 oz. per gallon). Do not use an alcohol based stabilizer (ethanol or methanol).

**Note:** A fuel stabilizer/conditioner is most effective when mixed with fresh gasoline and used at all times.

- B. Run the engine to distribute conditioned fuel through the fuel system (5 minutes).
- C. Stop the engine, allow it to cool, and drain the fuel tank.
- D. Restart the engine and run it until it stops.
- E. Start and run the engine until it will not start again.
- F. Dispose of fuel properly. Recycle as per local codes.

**Important:** Do not store stabilizer/conditioned gasoline over 90 days

9. Remove the spark plugs and check their condition; refer to Changing the Spark Plugs.

10. With the spark plugs removed from the engine, pour two tablespoons of engine oil into the spark plug hole.
11. Use the starter to crank the engine and distribute the oil inside the cylinder.
12. Install the spark plugs and tighten to recommended torque; refer to Changing the Spark Plugs.

**Note:** Do not install the wire on the spark plug(s).

13. Check anti freeze protection and add a 50/50 solution of water and anti freeze as needed for expected minimum temperature in your area.
14. Remove the battery from the chassis, check the electrolyte level, and charge it fully; refer to Servicing the Battery.

**Note:** Do not connect the battery cables to the battery posts during storage.

**Important:** The battery must be fully charged to prevent it from freezing and being damaged at temperatures below 32°F (0°C). A fully charged battery maintains its charge for about 50 days at temperatures lower than 40°F (4°C). If the temperatures will be above 40°F (4°C), check the water level in the battery and charge it every 30 days.

15. Check and tighten all bolts, nuts, and screws. Repair or replace any part that is damaged.
16. Paint all scratched or bare metal surfaces.  
Paint is available from your Authorized Service Distributor.
17. Store the machine in a clean, dry garage or storage area.
18. Remove the ignition key and put it in a safe place out of the reach of children.
19. Cover the machine to protect it and keep it clean.

# Schematics

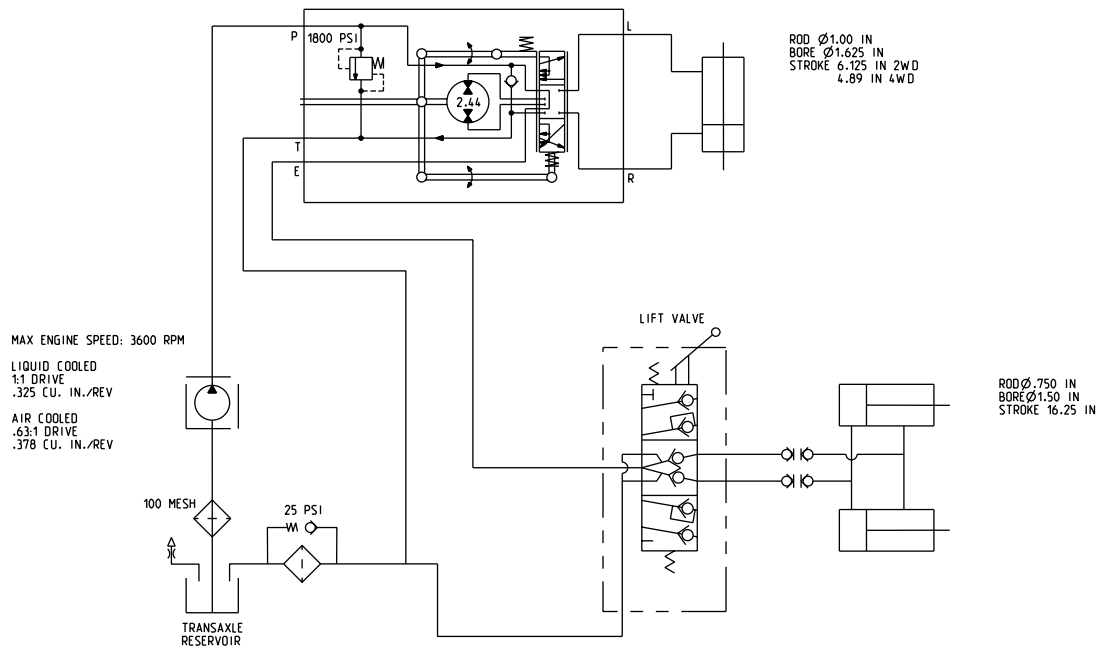

**Hydraulic Schematic (Rev. B)**

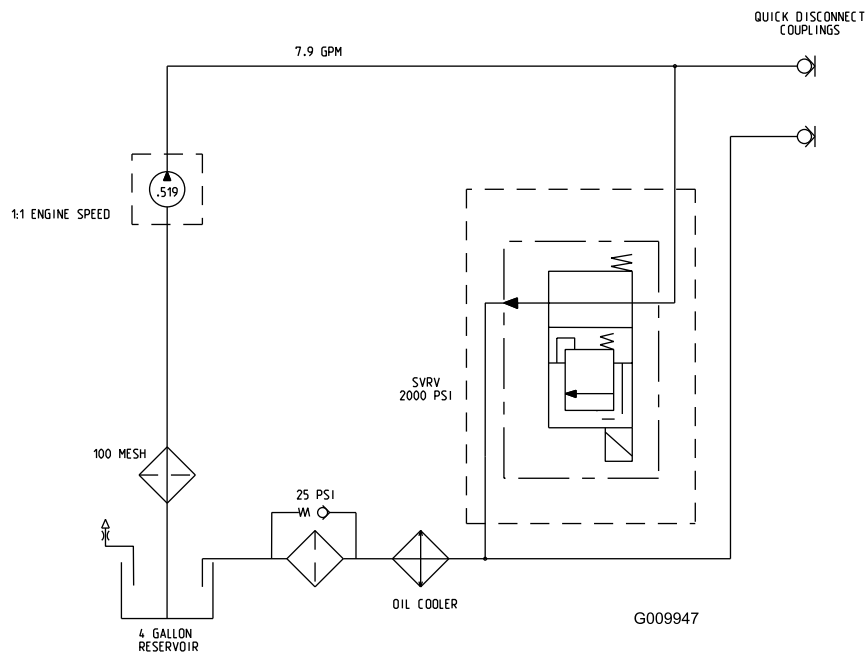

**High Flow Hydraulics Schematic (TC models only) (Rev. A)**

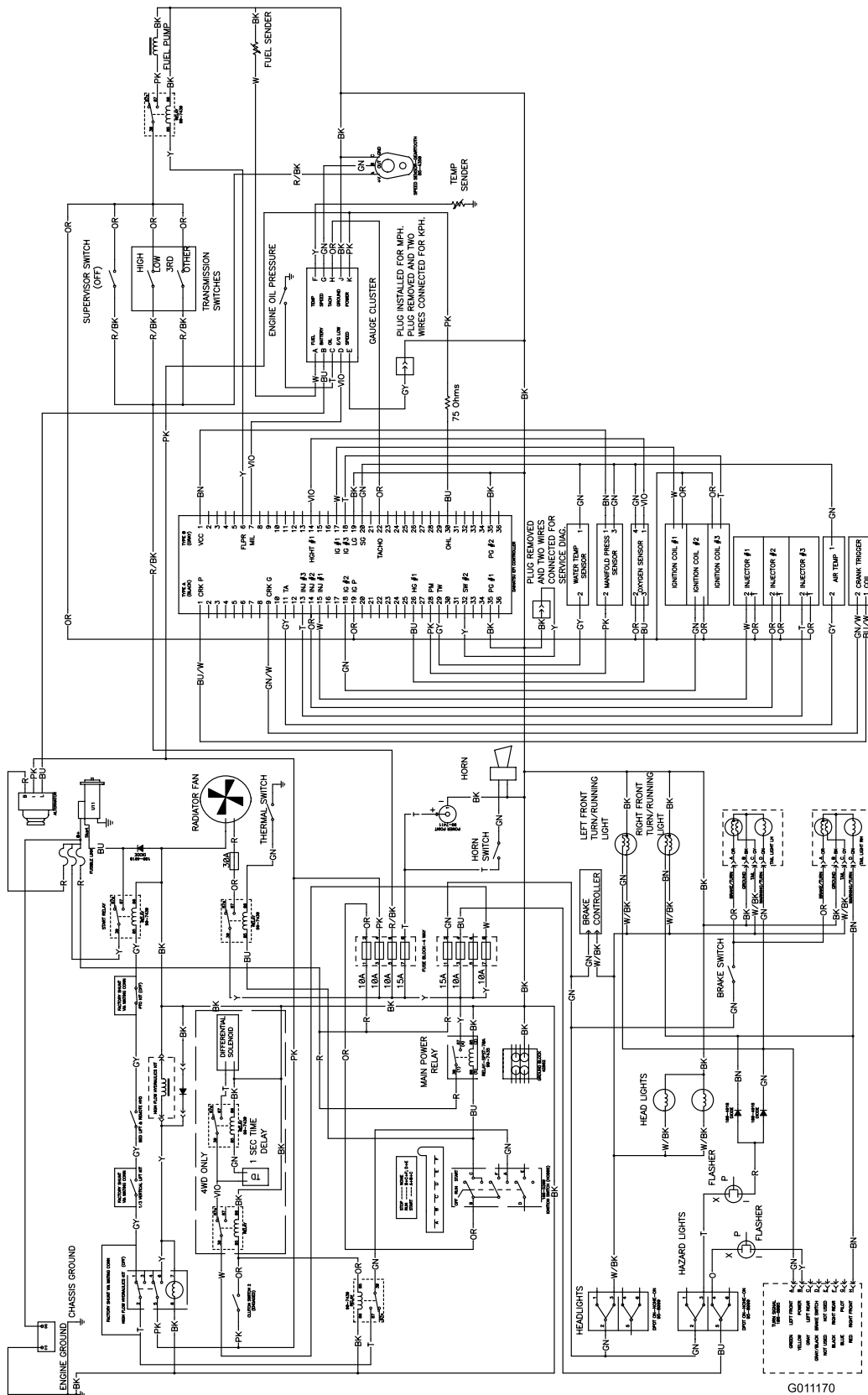

Electrical Schematic (Rev. B)

G011170

# Notes:

**Notes:**

# The Toro Total Coverage Guarantee

## A Limited Warranty

### Conditions and Products Covered

The Toro® Company and its affiliate, Toro Warranty Company, pursuant to an agreement between them, jointly warrant your Toro Commercial product ("Product") to be free from defects in materials or workmanship for two years or 1500 operational hours\*, whichever occurs first. This warranty is applicable to all products with the exception of Aerators (refer to separate warranty statements for these products). Where a warrantable condition exists, we will repair the Product at no cost to you including diagnostics, labor, parts, and transportation. This warranty begins on the date the Product is delivered to the original retail purchaser. \* Product equipped with an hour meter.

### Instructions for Obtaining Warranty Service

You are responsible for notifying the Commercial Products Distributor or Authorized Commercial Products Dealer from whom you purchased the Product as soon as you believe a warrantable condition exists. If you need help locating a Commercial Products Distributor or Authorized Dealer, or if you have questions regarding your warranty rights or responsibilities, you may contact us at:

Commercial Products Service Department  
Toro Warranty Company  
8111 Lyndale Avenue South  
Bloomington, MN 55420-1196  
E-mail: commercial.warranty@toro.com

### Owner Responsibilities

As the Product owner, you are responsible for required maintenance and adjustments stated in your Operator's Manual. Failure to perform required maintenance and adjustments can be grounds for disallowing a warranty claim.

### Items and Conditions Not Covered

Not all product failures or malfunctions that occur during the warranty period are defects in materials or workmanship. This warranty does not cover the following:

- Product failures which result from the use of non-Toro replacement parts, or from installation and use of add-on, or modified non-Toro branded accessories and products. A separate warranty may be provided by the manufacturer of these items.
- Product failures which result from failure to perform recommended maintenance and/or adjustments. Failure to properly maintain your Toro product per the Recommended Maintenance listed in the *Operator's Manual* can result in claims for warranty being denied.
- Product failures which result from operating the Product in an abusive, negligent or reckless manner.
- Parts subject to consumption through use unless found to be defective. Examples of parts which are consumed, or used up, during normal Product operation include, but are not limited to, brakes pads and linings, clutch linings, blades, reels, bed knives, tines, spark plugs, castor wheels, tires, filters, belts, and certain sprayer components such as diaphragms, nozzles, and check valves, etc.
- Failures caused by outside influence. Items considered to be outside influence include, but are not limited to, weather, storage practices, contamination, use of unapproved coolants, lubricants, additives, fertilizers, water, or chemicals, etc.

### Countries Other than the United States or Canada

Customers who have purchased Toro products exported from the United States or Canada should contact their Toro Distributor (Dealer) to obtain guarantee policies for your country, province, or state. If for any reason you are dissatisfied with your Distributor's service or have difficulty obtaining guarantee information, contact the Toro importer. If all other remedies fail, you may contact us at Toro Warranty Company.

- Normal noise, vibration, wear and tear, and deterioration.
- Normal "wear and tear" includes, but is not limited to, damage to seats due to wear or abrasion, worn painted surfaces, scratched decals or windows, etc.

### Parts

Parts scheduled for replacement as required maintenance are warranted for the period of time up to the scheduled replacement time for that part. Parts replaced under this warranty are covered for the duration of the original product warranty and become the property of Toro. Toro will make the final decision whether to repair any existing part or assembly or replace it. Toro may use remanufactured parts for warranty repairs.

### Note Regarding Deep Cycle Battery Warranty:

Deep cycle batteries have a specified total number of kilowatt-hours they can deliver during their lifetime. Operating, recharging, and maintenance techniques can extend or reduce total battery life. As the batteries in this product are consumed, the amount of useful work between charging intervals will slowly decrease until the battery is completely worn out. Replacement of worn out batteries, due to normal consumption, is the responsibility of the product owner. Battery replacement may be required during the normal product warranty period at owner's expense.

### Maintenance is at Owner's Expense

Engine tune-up, lubrication cleaning and polishing, replacement of Items and Conditions Not Covered filters, coolant, and completing Recommended Maintenance are some of the normal services Toro products require that are at the owner's expense.

### General Conditions

Repair by an Authorized Toro Distributor or Dealer is your sole remedy under this warranty.

**Neither The Toro Company nor Toro Warranty Company is liable for indirect, incidental or consequential damages in connection with the use of the Toro Products covered by this warranty, including any cost or expense of providing substitute equipment or service during reasonable periods of malfunction or non-use pending completion of repairs under this warranty. Except for the Emissions warranty referenced below, if applicable, there is no other express warranty.**

All implied warranties of merchantability and fitness for use are limited to the duration of this express warranty. Some states do not allow exclusions of incidental or consequential damages, or limitations on how long an implied warranty lasts, so the above exclusions and limitations may not apply to you.

This warranty gives you specific legal rights, and you may also have other rights which vary from state to state.

### Note regarding engine warranty:

The Emissions Control System on your Product may be covered by a separate warranty meeting requirements established by the U.S. Environmental Protection Agency (EPA) and/or the California Air Resources Board (CARB). The hour limitations set forth above do not apply to the Emissions Control System Warranty. Refer to the Engine Emission Control Warranty Statement printed in your *Operator's Manual* or contained in the engine manufacturer's documentation for details